

INSTRUCTION MANUAL

6 1/2 DIGITAL MULTIMETER DL-1060 DL-1060G/ DL-1060VG DL-1060R/ DL-1060VR



CONTENTS

USING THE PRODUCT SAFELY.....	I - III
1 OVERVIEW	1
1.1 GENERAL INFOMATION	1
1.1.1 Feature Overview	1
1.1.2 Inspection	2
1.1.3 Taking off the black rubber ring.....	2
1.1.4 The DL-1060's Dimension	3
1.1.5 Update of the user's manual.....	3
1.2 SETTING UP DL-1060	4
1.2.1 To adjust the handle.....	4
1.2.2 To connect the power	6
1.2.2.1 To convert the voltage	6
1.2.2.2 To change the power-line fuse.....	9
1.2.2.3 To change the current input fuse.....	13
1.2.3 Factory Default When Power-ON	16
1.3 DL-1060 FUNCTION INTRODUCTION	17
1.3.1 The Front Panel	17
1.3.2 The Display	19
1.3.2.1 Annunciators.....	19
1.3.3 The Rear Panel.....	20
2 BASIC MEASUREMENT FUNCTION	21
2.1 VOLTAGE MEASUREMENTS (DCV & ACV).....	21
2.2 RATIO MEASUREMENTS (DC VOLTAGE ONLY).....	22
2.3 CURRENT MEASUREMENTS (DC & AC)	24
2.4 RESISTANCE MEASUREMENTS (2 & 4-WIRE).....	25
2.5 FREQUENCY & PERIOD MEASUREMENTS.....	26
2.6 CONTINUITY MEASUREMENTS.....	28
2.7 DIODE MEASUREMENTS.....	29
2.8 TEMPERATURE MEASUREMENTS	30
2.8.1 Thermocouple Measurements	31
2.8.2 RTD Measurements	31
2.8.2.1 2-Wire RTD Measurements.....	32
2.8.2.2 3-Wire RTD Measurements.....	32
2.8.2.3 4-Wire RTD Measurements.....	33
2.9 CAPACITANCE MEASUREMENTS	34
2.10 2ND MEASUREMENT.....	35
3 FRONT PANEL OPERATIONS	38
3.1 MEASUREMENT CONFIGURATION.....	38
3.1.1 Set ADC (Auto Zero)	38
3.1.2 Filter	40
3.1.2.1 AC Filter (AC only)	40
3.1.2.2 Digital Filter	41
3.1.3 Resolution & NPLC Setting	44
3.1.4 Threshold Resistance (Continuity)	46
3.1.5 Range (Manual & Auto).....	47
3.1.6 Rate (Integration Time)	48
3.1.7 Sensor Selection for Temperature Measurements.....	50
3.1.8 Remote Interface Selection	55
3.2 TRIGGER OPERATIONS.....	58
3.2.1 Trigger Mode	59
3.2.2 Trigger Source	61
3.2.3 Trigger Setting	62
3.3 MATH OPERATIONS	66
3.3.1 Percent(%).....	67
3.3.2 Average (AVG/MIN/MAX/COUNT).....	68
3.3.3 Null(Relative)	69
3.3.4 Limits Test	70
3.3.5 MX+B.....	72
3.3.6 dB/dBm	73

3.4	SYSTEM RELATED OPERATIONS	76
3.4.1	Display	76
3.4.2	Beeper	77
3.4.3	Reading Memory (Store & Recall)	79
3.4.4	Sensitivity Band (Hold).....	80
3.4.5	Initial Mode.....	82
3.4.6	Language.....	83
3.4.7	Error Condition.....	83
3.4.8	Firmware Revision	84
3.4.9	Calibration.....	84
3.4.10	Self-test	85
4	REMOTE INTERFACE OPERATIONS	86
4.1	PASS/FAIL OUTPUT FROM USB CONNECTOR.....	86
4.2	SETTING UP FOR REMOTE INTERFACE	87
4.3	REMOTE INTERFACE COMMANDS.....	88
5	ERROR MESSAGE	98
5.1	ERROR TYPE.....	98
5.1.1	Execution Errors.....	98
APPENDIX	102
A.	SPECIFICATION LIST	102
B.	REMOTE INTERFACE REFERENCE	106
B.1	An Introduction to the SCPI Language.....	106
B.2	Output Data Formats	109
B.3	The MEASure? Command	109
B.4	The CONFigure Command	111
B.5	The Measurement Configuration Command.....	112
B.6	The Math Operation Command	117
B.7	The Triggering Commands.....	119
B.8	The System-Related Commands.....	120
B.9	The SCPI Status Reporting	123
B.10	Status Reporting Commands	127
B.11	SCPI Compliance Information	128
B.12	GP-IB (IEEE-488) Compliance Information	129
C.	ABOUT APPLICATION PROGRAMS	131
C.1	Using MEASure? for a Single Measurement	131
C.2	Using CONFigure with a Math Operation	133
C.3	THE DEVQUERY FUNCTION	136





USING THE PRODUCT SAFELY

■ Preface

To use the product safely, read this instruction manual to the end. Before using this product, understand how to correctly use it. If you read the manuals but you do not understand how to use it, ask us or your local dealer. After you read the manuals, save it so that you can read it anytime as required.

■ Pictorial indication and warning character indication

The manuals and product show the warning and caution items required to safely use the product. The following pictorial indication and warning character indication are provided.

<Pictorial indication>	
	<p>Some parts of this product or certain sections of the user's guide may show this pictorial indication. In this case, if that part of the product is used incorrectly, the user's body or the product may be exposed to serious danger. Be sure to refer to this user's guide when using parts with this pictorial indication.</p>
	<p>Some part of this product or the manuals may show this pictorial indication. In this case, there are high voltage points. Be careful enough to handle the product to avoid electric shock.</p>
	<p>If you ignore this indication and incorrectly use the product, you may be killed or seriously injured. This indication means that a warning item is provided in order to avoid extreme risk.</p>
	<p>If you ignore this indication and incorrectly use the product, you may suffer slight injury or the product may be damaged. This indication means that a caution item is provided in order to avoid risk.</p>

Please be informed that we are not responsible for any damages to the user or to the third person, arising from malfunctions or other failures due to wrong use of the product or incorrect operation, except such responsibility for damages as required by law.

USING THE PRODUCT SAFELY



■ Do not remove the product's covers and panels

Never remove the product's covers and panels for any purpose. Otherwise, the user's electric shock or fire may be incurred.

■ Warning on using the product

Warning items given below are to avoid danger to user's body and life and avoid the damage or deterioration of the product. Use the product, observing the following warning and caution items.

■ Warning items on power supply

● Power supply voltage

The rated power supply voltages of the product are 100, 120, 220, and 240VAC. The rated power supply voltage for each product should be confirmed by reading the label attached on the back of the product or by the "rated" column shown in the instruction manual. The specification of power cord attached to the products is rated to 125VAC for all products which are designed to be used in the areas where the power-line voltage is not higher than 125VAC. Accordingly, you must change the power cord if you want to use the product at the power supply voltage higher than 125VAC. If you use the product without changing power cord to 250VAC rated one, electric shock or fire may be caused. When you used the product equipped with power supply voltage switching system, please refer to the corresponding chapter in the instruction manuals of each product.

● Power cable

Important: The attached power cord set can be used for this device only.

If the attached power cord is damaged, stop using the product and call us or your local dealer. If the power cord is used without the damage being removed, an electric shock or fire may be caused.

● Protective fuse

If an input protective fuse is blown, the product does not operate. For a product with external fuse holder, the fuse may be replaced. As for how to replace the fuse, refer to the corresponding chapter in the instruction manual. If no fuse replacement procedures are indicated, the user is not permitted to replace it. In such case, keep the case closed and consult us or your local dealer. If the fuse is incorrectly replaced, a fire may occur.

■ Warning item on Grounding

If the product has the GND terminal on the front or rear panel surface, be sure to ground the product to safely use it.

■ Warnings on installation environment

● Operating temperature and humidity

Use the product within the operating temperature indicated in the "rating" temperature column. If the product is used with the vents of the product blocked or in high ambient temperatures, a fire may occur. Use the product within the operating humidity indicated in the "rating" humidity column. Watch out for condensation by a sharp humidity change such as transfer to a room with a different humidity. Also, do not operate the product with wet hands. Otherwise, an electric shock or fire may occur.

● Use in gas

Use in and around a place where an inflammable or explosive gas or steam is generated or stored may result in an explosion and fire. Do not operate the product in such an environment. Also, use in and around a place where a corrosive gas is generated or spreading causes a serious damage to the product. Do not operate the product in such an environment.

● Installation place

Avoid installing the product on inclined places or on places subject to vibration. Otherwise, the product may slip or fall down to cause damages or injury accidents.

USING THE PRODUCT SAFELY

■ Do not let foreign matter in

Do not insert metal and inflammable materials into the product from its vent and spill water on it. Otherwise, electric shock or fire may occur.

■ Warning item on abnormality while in use

If smoke or fire is generated from the product while in use, stop using the product, turn off the switch, and remove the power cord plug from the outlet. After confirming that no other devices catch fire, ask us or your local dealer.

■ Input/output terminal

Maximum input to terminal is specified to prevent the product from being damaged. Do not supply input, exceeding the specifications that are indicated in the "Rating" column in the instruction manual of the product. Also, do not supply power to the output terminals from the outside. Otherwise, a product failure is caused.

■ Calibration

Although the performance and specifications of the product are checked under strict quality control during shipment from the factory, they may be deviated more or less by deterioration of parts due to their aging or others. It is recommended to periodically calibrate the product so that it is used with its performance and specifications stable. For consultation about the product calibration, ask us or your local dealer.

■ Daily Maintenance

When you clean off the dirt of the product covers, panels, and knobs, avoid solvents such as thinner and benzene. Otherwise, the paint may peel off or resin surface may be affected. To wipe off the covers, panels, and knobs, use a soft cloth with neutral detergent in it. During cleaning, be careful that water, detergents, or other foreign matters do not get into the product. If a liquid or metal gets into the product, an electric shock and fire are caused. During cleaning, remove the power cord plug from the outlet.

Use the product correctly and safely, observing the above warning and caution items. Because the instruction manual indicates caution items even in individual items, observe those caution items to correctly use the product.

If you have questions or comments about the manuals, ask us or E-Mail us.

1 Overview

This chapter will give you an overview of DL-1060's features and guide you through the basics of DL-1060 digital multimeter

1.1 General Information

This section contains general information about DL-1060 Multimeter.

1.1.1 Feature Overview

DL-1060 series is a 6 1/2 digits multimeter. It has...

- Best performance/price ratio
- High-speed sampling rate (50000 Rdgs/sec. at NPLC 0.001)
- Direct Thermocouple Measurement (Built-In Cold Junction Compensation to improve Accuracy)
- Dual Measurement & Dual Display (Including Thermocouple Measurement)
- Capacitance Measurement
- Several Measurements & Mathematic Functions
- Wide Range Current Measurement (Up to 10A)
- DCV Accuracy (0.012% in 1 year)
- High Sensitivity (DCV: 0.1 μ V & Resistance: 100 $\mu\Omega$)
- Plug & Play Interface: Built-In USB (USB-TMC)
- High Storage Memory (Up to 2000 Readings)
- Free Application Software

In addition, the DL-1060 series provides wide ranges for general measurements, such as...

1. DCV: 100mV, 1V, 10V, 100V, and 1000V
2. ACV: 100mV, 1V, 10V, 100V, and 750V
3. DCI: 10mA, 100mA, 1A, 3A, and 10A
4. ACI: 1A, 3A, and 10A
5. 2 and 4-wired resistance: 100 Ω , 1K Ω , 10K Ω , 100K Ω , 1M Ω , 10M Ω , and 100M Ω
6. Capacitance: 1nF, 10nF, 100nF, 1 μ F, 10 μ F, 100 μ F, 1000 μ F, and 10000 μ F
7. Thermocouple: -250 $^{\circ}$ C to 1820 $^{\circ}$ C
8. RTD: 2W and 4W
9. Frequency and Period: 100mV to 750V (From 3Hz to 300KHz)
10. Diode: 1V
11. Continuity (for 2W): 1000 Ω

Some additional capabilities of DL-1060 include:

- Full Math Functions - Percent, Average, Null, Limits, MX+B, dB, and dBm.
- Resolution Adjustment - 0.001, 0.006, 0.02, 0.06, 0.2, 0.6, 1, 2, 10, and 100 NPLC
- USB, GP-IB(DL-1060G/VG), and RS-232C(DL-1060R/VR) remote control interface.
- Through DL-1060 AP software (DL-TOOL) for simulating the real operation on PC.
- Through Microsoft Office Word & Excel (DL-LINK) for remotely storing and recalling the measured values.

1.1.2 Inspection

Your product package is supplied with the following items:

- One DL-1060 Multimeter unit.
- One power line cord.
- One USB cable.
- Standard Test Leads[1]
- One CD (including this electronic User's Manual and software applications).

[1] DL-1060 series is provided with a Standard Test Lead set, described below.

Test Lead Ratings:	Material:
IEC 61010-031 CAT III Operating Voltage: 1000V DC Current: 10 Amperes UL/CE Rated	Probe Body: Outer Insulation-Santoprene Rubber. Banana Plug: Body Brass, Nickel Plated Spring Beryllium Copper, Nickel Plated. Insulation: Polypropylene Resin Flame Retardant Grade 2038.

Others: If any part of the Test Lead Set is damaged, please do not use and replace with a new set.



If users use the Test Lead Set without following the specification of DL-1060, the protection of the Test Lead Set could be impaired. In addition, please don't use a damaged Test Lead Set against the instrument break or personal injury.

1.1.3 Taking off the black rubber ring



Before using the DL-1060 DMM, taking off the black rubber ring from the Power Switch

1.1.4 The DL-1060's Dimension

Please get the dimension's information in the following different ways.

1. The dimension without the handle and the front & Rear Bumpers is in the following **Figure 1-1**. (L x W x D - 214.6 x 88.6 x 280.7 mm)
2. The dimension with the handle and the front & Rear Bumpers is in the following **Figure1-2**. (L x W x D . 252.8 x 107 x 305 mm)
3. The dimension with the front & Rear Bumpers, but without the handle is in the following **Figure 1-3**. (L x W x D . 226.8 x 107 x 305 mm)

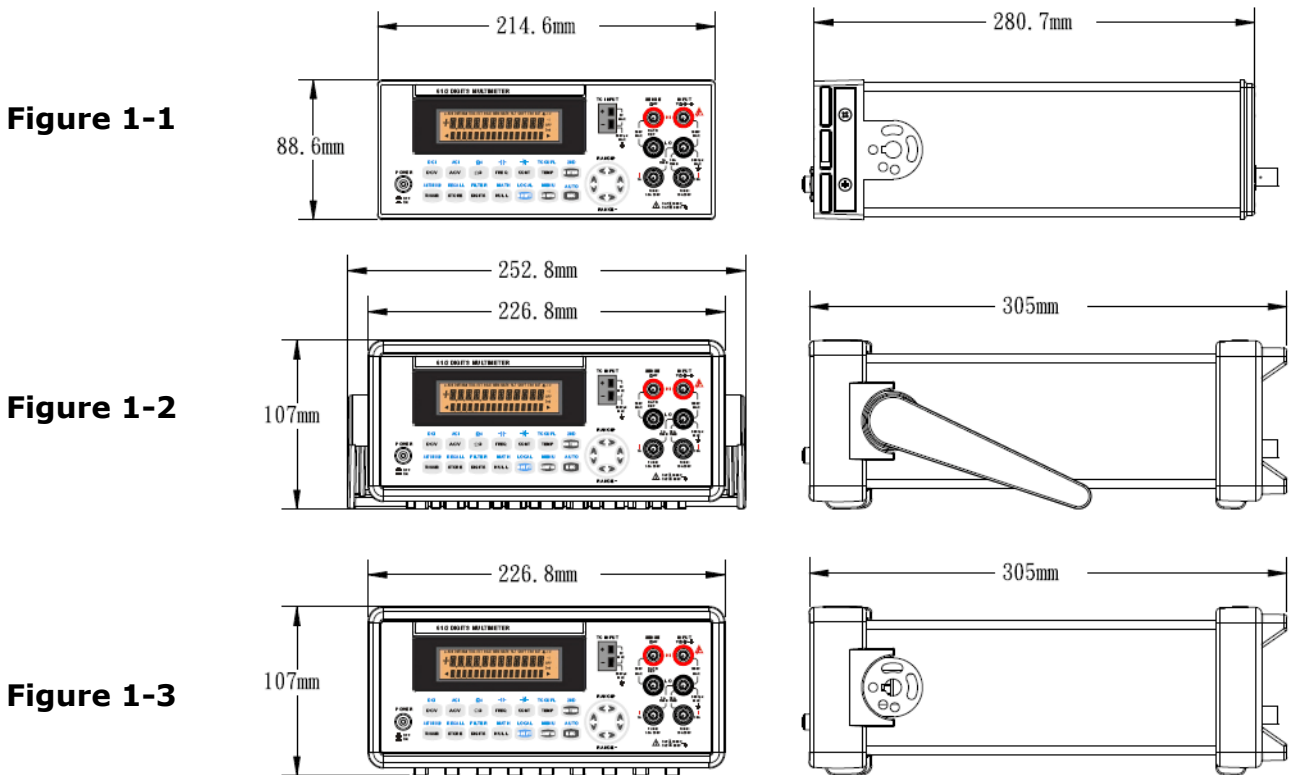

1.1.5 Update of the user's manual

To update the user's manual, please check our web site. The last update may be downloaded from the web site.

(<http://www.texio.co.jp/>)

1.2 Setting up DL-1060

The purpose of this section is to prepare you for using DL-1060 DMM. You may want to check if you have all the parts with your multimeter. All our products are handled and inspected professionally before shipping out to our customers. If you find any damaged or missing parts, please contact your local service representative immediately and do not attempt to operate the damaged product.

1.2.1 To adjust the handle

You may adjust the carrying handle to suit your needs. The following figures shows you how to adjust the handle.

I. Taking off the handle from the Multimeter

【Step 1】 (Turn up the handle)

Pull slightly outward on both sides of the handle and slowly rotate it up as shown in **Figure 1-4**.

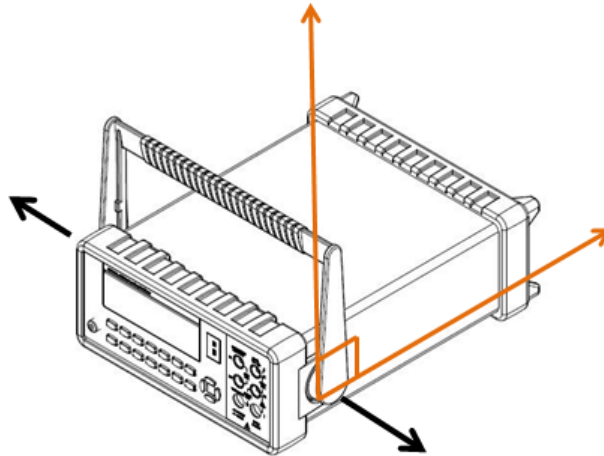

Figure 1-4

【Step 2】 (Pull out the handle)

When the handle is turned up to 90° with the multimeter please pull out the handle from the multimeter as shown in **Figure 1-5**.

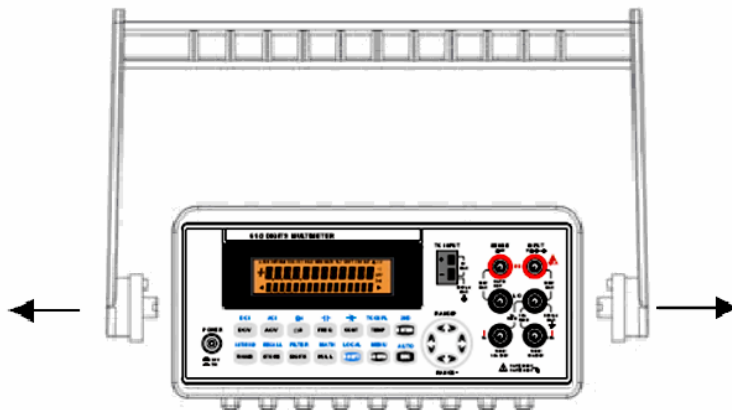

Figure 1-5

II. Adjusting the position for your convenience

Here are some example positions to for your reference.

【Position 1】

The default position is for packing as shown in **Figure 1-6**.

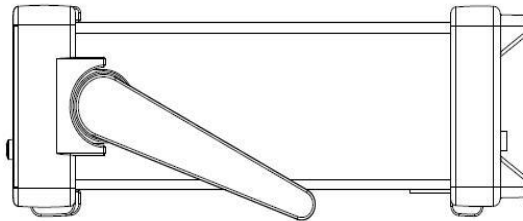

Figure 1-6

【Position 2】

The position shown in **Figure 1-7** is for operating the multimeter.

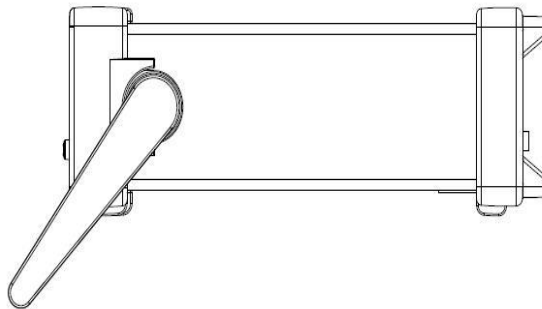

Figure 1-7

【Position 3】

The position shown in **Figure 1-8** is for carrying the multimeter.

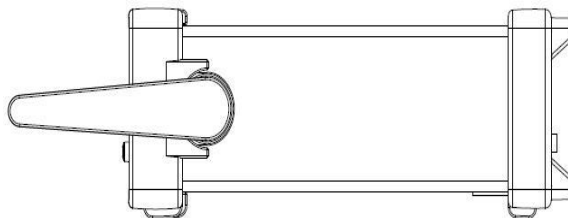

Figure 1-8

1.2.2 To connect the power

Check the power-line voltage on the rear panel to see if voltage setting is correct for your area. Change the voltage correctly or replace a new fuse if the voltage is not correct or the fuse is broken. Please follow the steps below.

1.2.2.1 To convert the voltage



In some areas, the power supplied voltage is 240Vac or 120Vac; in others, the power supplied voltage is 220 Vac or 100 Vac. Please refer to your local power supplied voltage to see if you have the right setting.



Before changing the setting, make sure the multimeter is disconnected from the AC power. An incorrect voltage setting may cause severe damage to your instrument. The power cord supplied with DL-1060 contains a separate ground wire for use with grounded outlets. When proper connections are made, instrument chassis is connected to power line ground through the ground wire in the power cord. Failure to use a grounded outlet may result in personal injury or death due to electric shock.



Suppose your multimeter is under the AC 220V condition and you want to convert it to 100V. Follow the following steps to change the voltage setting.

【Step 1】

Verify that the DMM is disconnected as shown in **Figure 1-9**.

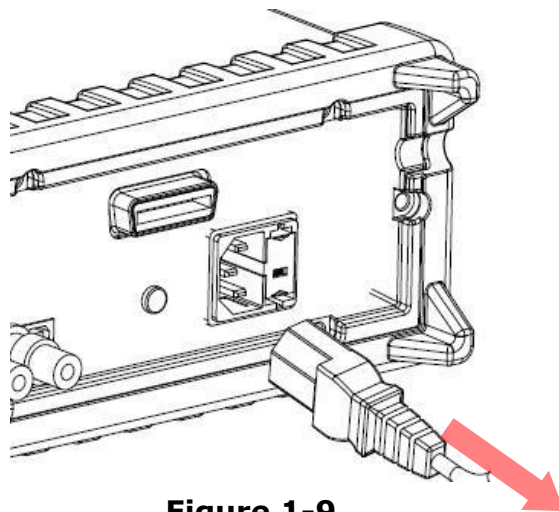

Figure 1-9

【Step 2】

Press the latch to unlatch the voltage setting selector container as shown in **Figure 1-10**. (You may need a screwdriver to do so.)

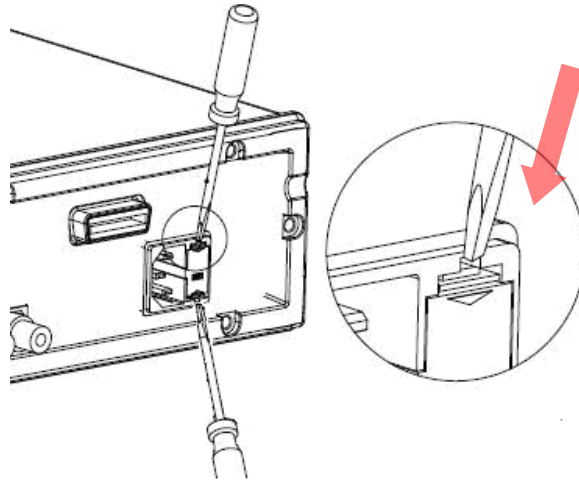

Figure 1-10

【Step 3】

Remove the voltage setting selector container as shown in **Figure 1-11**. (You may need a screwdriver to do so.)

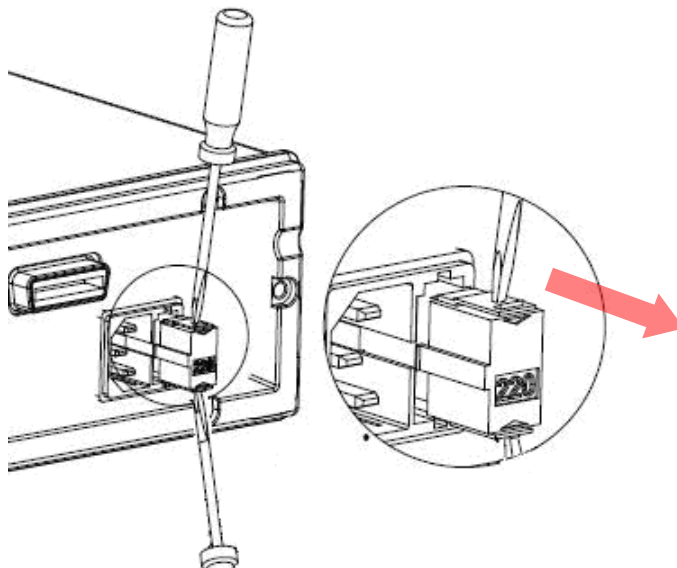

Figure 1-11

【Step 4】

Open the clips on the sides and remove the voltage setting selector from the container as shown in **Figure 1-12**.

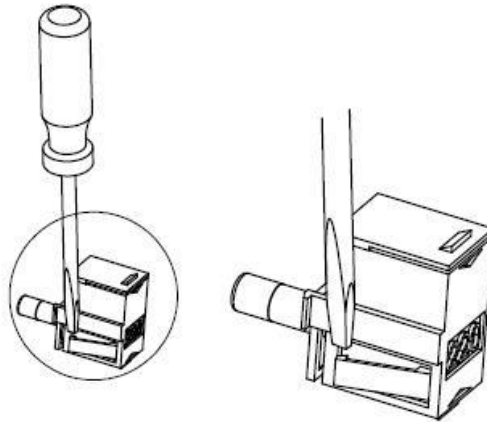

Figure 1-12

【Step 5】

Turn the voltage setting selector so that the desired voltage setting appears in the container as shown in **Figure 1-13**.

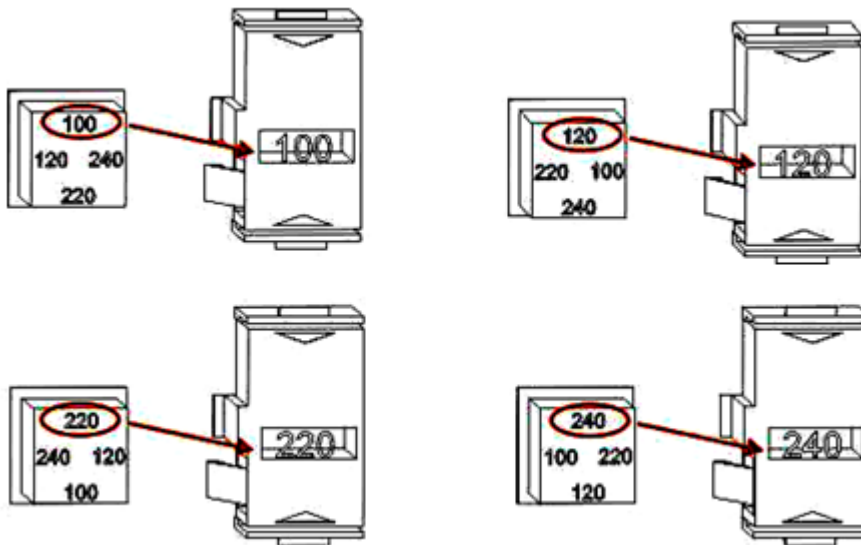

Figure 1-13

【Step 6】

Insert the voltage setting selector container back into the socket.

1.2.2.2 To change the power-line fuse



Before replacing the power-line fuse, make sure the multimeter is disconnected from the AC power. You must be qualified personnel to perform this action.



For continued protection against fire or instrument damage, only replace with fuse of the same type and rating noted on the rear panel. If the instrument repeatedly blows fuses, locate and correct the cause of the trouble before replacing the fuse. (Fuse to replace: 250VT250mA)

Verify that the power-line fuse is good. Replace the fuse if it is damaged.
Follow the steps below to change the fuse.

【Step 1】

Verify that the DMM is disconnected as shown in **Figure 1-14**.

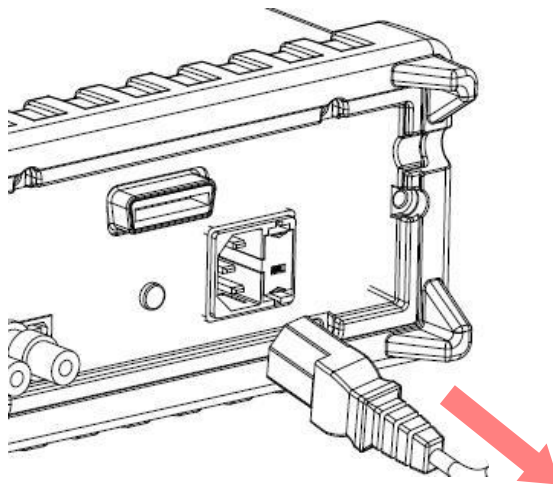

Figure 1-14

【Step 2】

Press the latch to unlatch the voltage setting selector container as shown in **Figure 1-15**. (You may need a screwdriver to do so.)

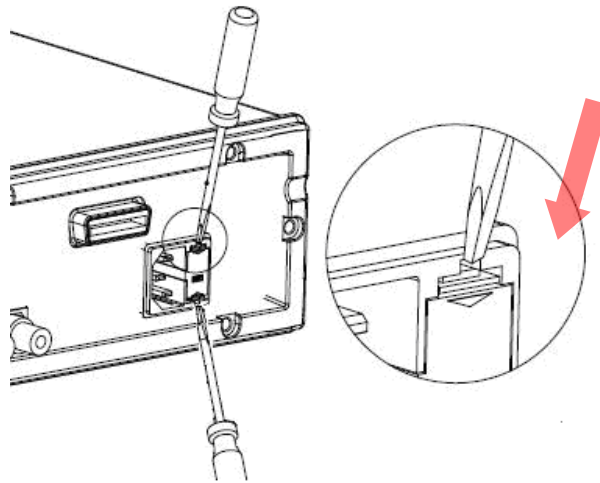

Figure 1-15

【Step 3】

Remove the voltage setting selector container as shown in **Figure 1-16**. (You may need a screwdriver to do so.)

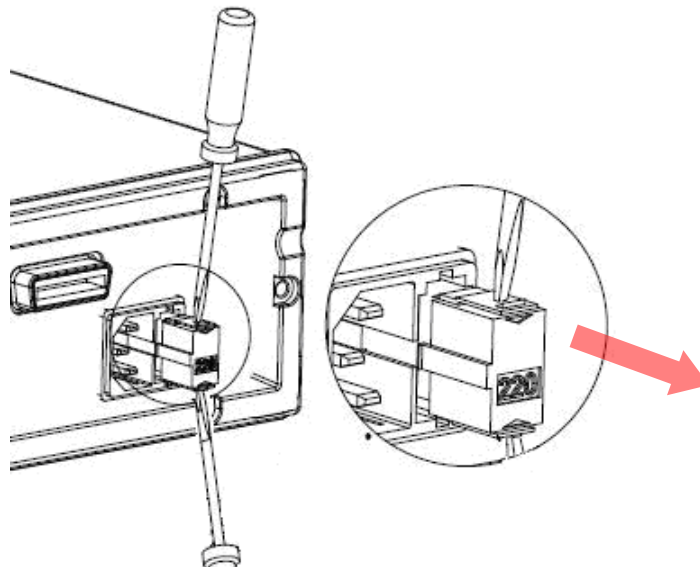

Figure 1-16

【Step 4】

Remove the broken fuse from the container as shown in **Figure 1-17**.

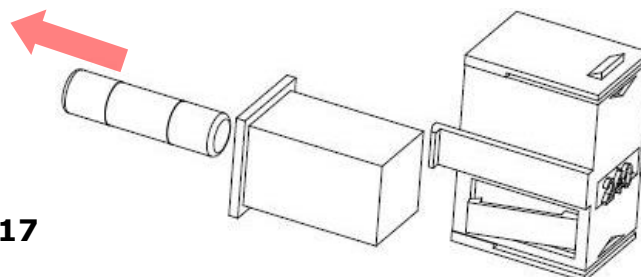

Figure 1-17

【Step 5】

Replace with the new standard fuse.

【Step 6】

Insert the voltage setting selector container back into the.

【Step 7】

Make sure the power switch on the front panel is in "Power OFF" condition before plugging as shown in **Figure 1-18**.



Figure 1-18

【Step 8】

After finishing the above procedures, you can plug in your power cord as shown in **Figure 1-19**.

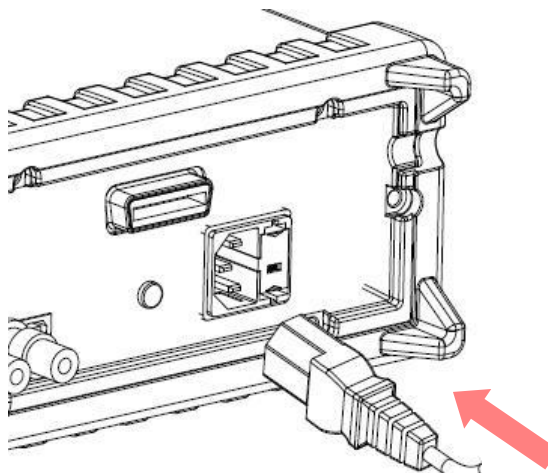

Figure 1-19

【Step 9】

Press on the power switch on the front panel for activating DL-1060 as shown in **Figure 1-20**.

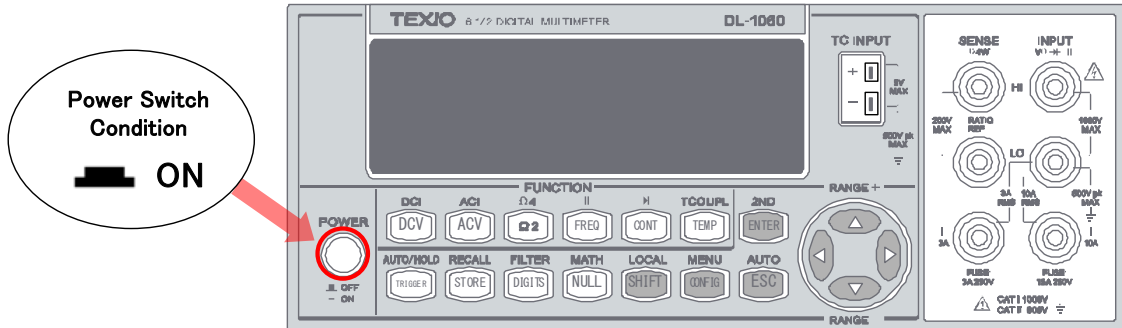

Figure 1-20

1.2.2.3 To change the current input fuse

The current input terminals are protected respectively by the fuses(3A,250V Fast Acting, HBC : Our part number F50-0268-08 or 15A,250V Fast Acting, HBC : Our part number F50-0269-08) at front panel.



Before replacing the current input fuse, make sure the multimeter is disconnected from the AC power. You must be qualified personnel to perform this action.



For continued protection against fire or instrument damage, only replace fuse with of the same type and rating noted on the rear panel. If the instrument repeatedly blows fuses, locate and correct the cause of the trouble before replacing the fuse.

Current Input Fuse Replacement (10A on the Front Panel)

Verify that the power-line fuse is good. Replace the fuse if it is damaged. Use only the same type and same rating fuse. (15A,250V Fast Acting, HBC : Our part number F50-0269-08) Please follow the steps below to change the fuse.

【Step 1】

Verify that the DMM is disconnected as shown in **Figure 1-21**.

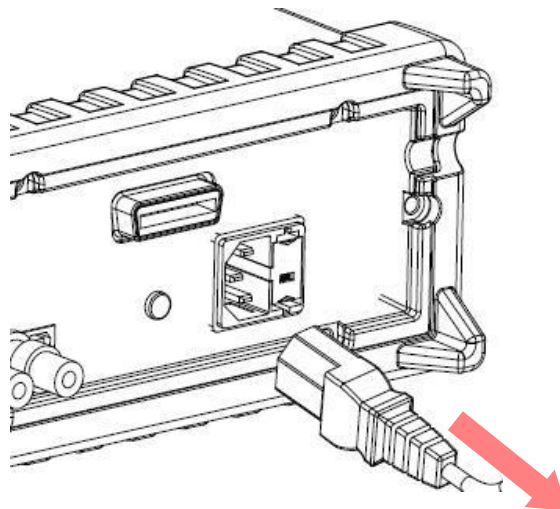

Figure 1-21

【Step 2】

Push the current input terminal and turn it right as shown in **Figure 1-22**.

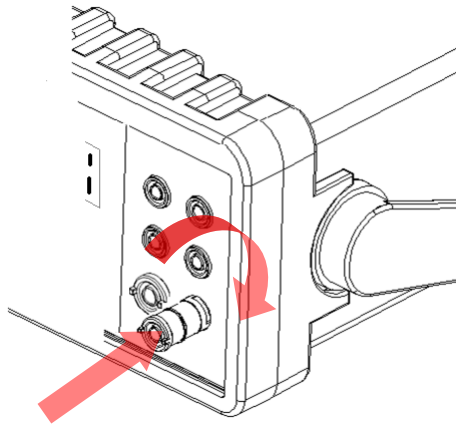

Figure 1-22

【Step 3】

Pull out the terminal (fuse holder) gently and you will find the current input fuse as shown in **Figure 1-23**.

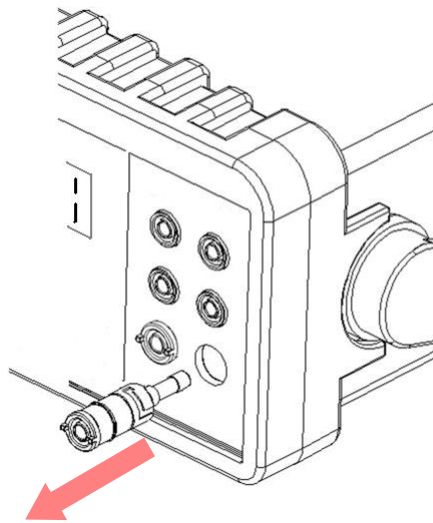

Figure 1-23

【Step 4】

Remove the broken fuse and replace a new one with the same type or same rating as shown in **Figure 2-19**.

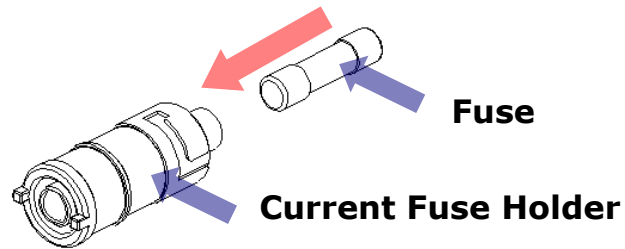

Figure 1-24

【Step 5】

Insert the fuse holder back and turn it left as shown in **Figure 1-25**. Make sure the fuse holder is properly seated and secured.

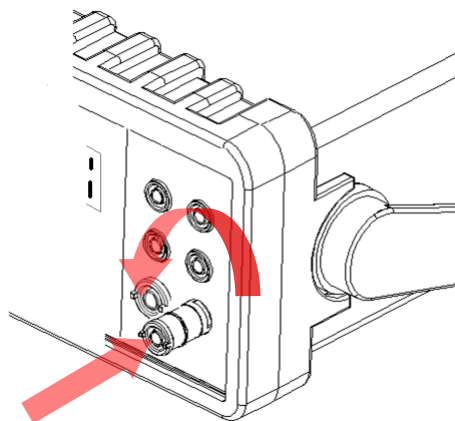

Figure 1-25

1.2.3 Factory Default When Power-ON

Table 1-1 shows the factory default of DL-1060.

Table 1-1

Function		Default
Location after Power On		DCV
Autozero		On
Frequency and Period Source		AC Voltage
Output Format		ASCII
Ratio		Off
AC Voltage	AC Bandwidth	20Hz
	AC Digits	5 1/2
	Range	Auto
DC Voltage	DC Digits	6 1/2 (10 PLC)
	Range	Auto
AC Current	AC Bandwidth	20Hz
	AC Digits	5 1/2
	Range	Auto
DC Current	DC Digits	6 1/2 (10 PLC)
	Range	Auto
Frequency and Period	Digits	5 1/2
	Range	AUTO
	Gate Time	0.1 Sec.
Capacitance	Digits	4 1/2
	Range	AUTO
Diode Test	Digits	5 1/2
	Range	1mA
	Rate	0.1 PLC
Resistance (2/4-wire)	Digits	6 1/2 (10 PLC)
	Range	AUTO
Temperature	Digits	6 1/2 (10 PLC)
	Thermocouple	K Type °C
Triggers	Source	Immediate
	Delay	AUTO
Input Resistance		10MΩ

1.3 DL-1060 Function Introduction

For users to become familiar with the DL-1060 DMM, we will give a brief introduction to the basic operations of DL-1060 DMM. There are three major parts of DL-1060: **(1.3.1) the front panel, (1.3.2) the display, and (1.3.3) the rear panel.** We will discuss each of them in the following sections.

1.3.1 The Front Panel

There are different buttons and terminals on the front panel. They are shown in **Figure 1-26.**

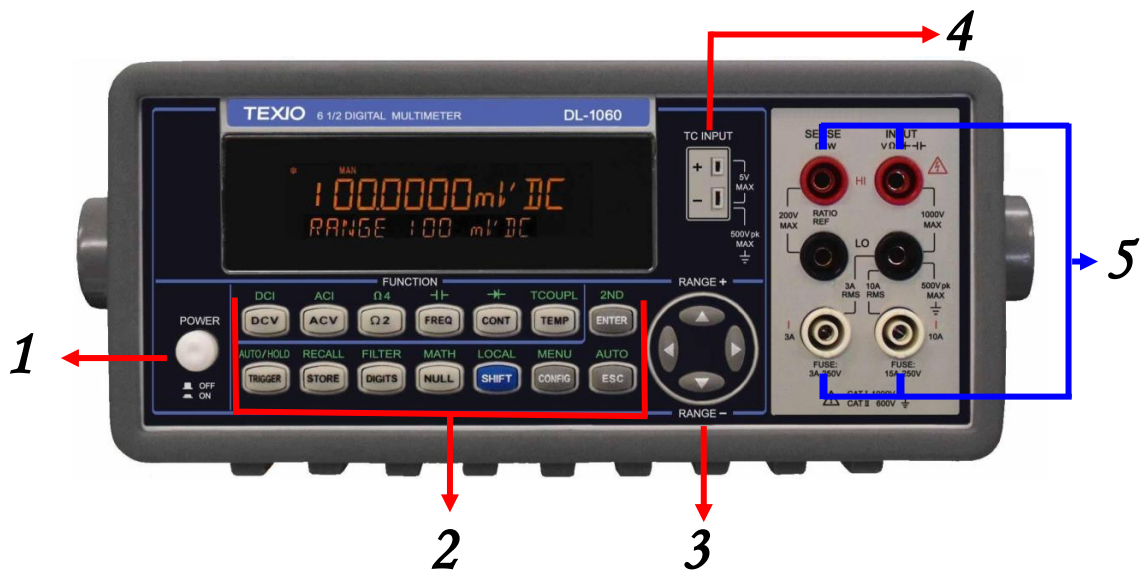

Figure 1-26

1. Power & Display:

- Power: Activates DL-1060 DMM.

2-1. First row without SHIFT button:

- DCV: Selects DC voltage measurement.
- ACV: Selects AC voltage measurement.
- $\Omega 2$: Selects 2-wire resistance measurement.
- FREQ: Selects frequency measurement.
- CONT: Selects the continuity test.
- TEMP: Selects RTD temperature measurement.
- ENTER: Accepts selection, moving to next choice or back to measurement display.

2-2. First row with SHIFT button:

- DCI: Selects DC current measurement.
- ACI: Selects AC current measurement.
- $\Omega 4$: Selects 4-wire resistance measurement.
- $\text{---}||\text{---}$: Selects capacitance measurement.

- : Selects diode testing.
- TCOUPL: Selects thermocouple temperature measurement.
- 2ND: Setting Secondary measurement.

2-3. Second row without SHIFT button:

- TRIGGER: Manually triggers the multimeter to make measurements or sets the multimeter to take external triggers.
- STORE: Stores a specified number of subsequent readings.
- DIGITS: Changes measurement resolution.
- NULL: Activates the null function in order to offset the measurement error due to the test leads.
- SHIFT (in blue): Used to access other functions in blue upper print.
- CONFIG: Configures the settings of selected measurement function.
- ESC: Cancels selection, moving back to measurement display.

2-4. Second row with SHIFT button:

- AUTO/HOLD: Enables or disables the reading hold function.
- RECALL: Displays stored readings. Use $\triangleleft \triangleright$ and $\triangle \nabla$ buttons to select a reading for display.
- FILTER: Enables or disables averaging digital filter.
- MATH: Enables or disables mathematical operations/tests including PERCENT, AVERAGE, NULL, LIMITS, MX+B, dB and dBm.
- LOCAL: Switches the multimeter to the local mode from the USB or GPIB remote mode.
- MENU: Offers system-wide settings, trigger settings, interface configurations and calibration information.
- AUTO: Enables auto range.

3. Range Section:

- $\triangleleft \triangleright$: Scrolls through options.
- $\triangle \nabla$: Changes the range while measuring or changes a digit when setting parameters.

4. TC INPUT section

The terminals at the TC INPUT section provide thermocouple temperature measurement. They come with built-in cold junction compensation so no extra thermocouple adapter is needed.

5. Inserted Connections & Fuse Device:

- HI & LO: Used for all measurements, except DC and AC current. (Maximum input voltage: 1000V for voltage measurements. 200V for 4-wire measurement)
- LO & I: Used for making DC and AC current measurements.
- Two Front Fuse: Protects current input terminal from overcurrent. (Maximum current: 3A, 250V and 15A 250V)

1.3.2 The Display

DL-1060 has a dual-LCD-display for a better view. There are two rows in the dual-display screen. The upper row (Primary) displays readings and units. A maximum 11 characters are allowed for upper row LCD display. The lower row (Secondary) displays range of the measurements, condition, the secondary readings & units or information about an ongoing configuration. A maximum 16 characters are allowed for lower row LCD display. There are additional annunciators at upper side and right side of the display screen for indicating the state or the condition of an ongoing measurement. They are explained individually in the following sections.



Figure 1-27

1.3.2.1 Annunciators

- ADR: Indicates the multimeter is via GPIB Interface.
- RMT (REMOTE): Indicates the remote state.
- MAN: Indicates the manual range is taken.
- TRIG: Shows the single triggering or the External Trigger is enabled.
- HOLD: Indicates reading hold function is enabled.
- MEM: Indicates the using of internal memory.
- MATH: Indicates the "MATH" operation is taken.
- FILT: The digital filter is started.
- SHIFT: Indicates SHIFT button is pressed.
- ERR: Error occurs.
- 4W: Indicates 4 -wire mode is selected for resistance measurement.
- ∙)): Indicates the continuity testing is enabled.
- OFF: Indicates the front panel display is turned off.
- RAT: Indicates the "RATIO" operation is taken.
- 2nd: Indicates 2ND function in use.

1.3.3 The Rear Panel

The rear panel of the DL-1060 is shown in **Figure 2-20**. This figure includes important abbreviated information that should be reviewed before using the instrument.

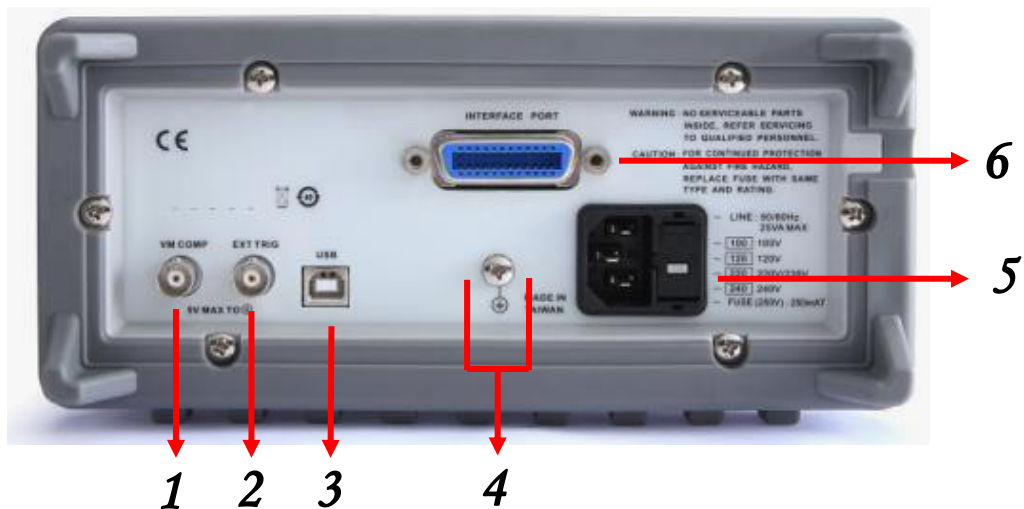

Figure 1-28

1. **VM COMP:** Voltmeter Complete Output Terminal. Outputs a low-true pulse from a remote interface.
2. **EXT TRIG:** Terminal to be used when choosing external triggering.
3. **USB Connection (USB-TMC):** Connects a remote computer for changing operation environment instead of the front panel control.
4. **Chassis ground terminal.**
5. **Power Module:** Contains the AC line receptacle, power line fuse, and line voltage setting. It is possible to switch 100Vac, 120Vac, 220Vac, and 240Vac along with the power-supply voltage selector which is equal to fuse folder.
6. **GPIB (IEEE488.2 Connection)/RS-232:**
Connects a remote computer with an IEEE488 cable or RS-232 card for changing operation environment instead of the front panel control (Model: DL-1060G/VG ,DL-1060R/VR).

2 Basic Measurement Function

This chapter introduces some basic measurement functions in DL-1060. You will learn how to use your DL-1060 multimeter to measure voltage, current, resistance, frequency, period, continuity, diode, temperature, capacitance and 2nd-Measurement in this chapter.

2.1 Voltage Measurements (DCV & ACV)

The ranges for DC voltage measurements in DL-1060 are 100mV, 1V, 10V, 100V and 1000V. For AC voltage measurements, the ranges are 100mV to 750V AC-Coupled T-RMS, or 1000V peak. **Figures 2-1** shows the locations of the buttons needed and message display for voltage measurement.



Warning: Do not apply more than 1000V (peak) to the multimeter. Applying excess voltage may damage your meter, or cause possible electric shock or personal injury.

※ Note: To eliminate the thermal EMFs due to the differences between two metals, use copper leads to connect your source signal to the meter.

How to measure voltage

1. Connect the test leads to the terminals on the front panel.
2. Set RESOLUTION of DCV (refer to 3.1.3 Resolution & NPLC Setting), BANDWIDTH of ACV (refer to 3.1.2.1 **AC Filter**) or skip this step if default is to be used.
3. Press DCV or ACV button for DC or AC voltage measuring.
4. Select auto-range function by pressing SHIFT + ESC button on the front panel or use \triangle and ∇ buttons to manually select desired range.
5. Connect test leads to your source signal and observe readings shown on the display. If the input signal is beyond the allowed range, an overflow message "OVLD" will be displayed.

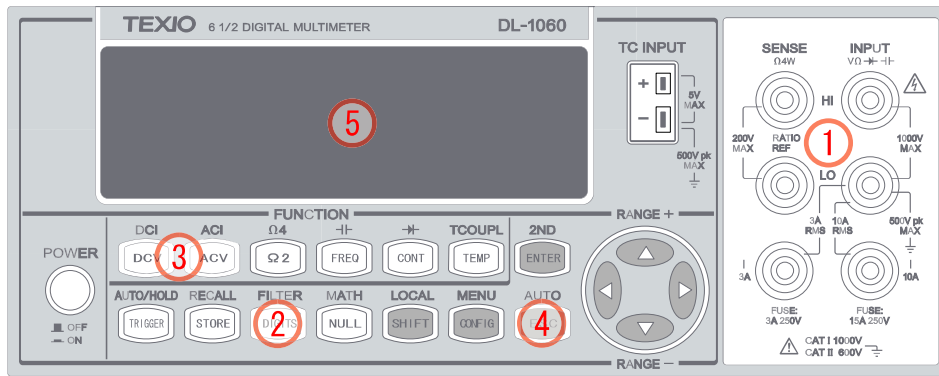

Figure 2-1

2.2 Ratio Measurements (DC Voltage only)

This function calculates the ratio of an input DC voltage to a reference DC voltage according to the following equation:

$$\text{Ratio} = \frac{\text{DC Input Voltage}}{\text{DC Reference Voltage}}$$

※ Note: This function only applies to DC voltage measurement.

How to make a ratio measurement

There are two ways to make a ratio measurement: Through the front panel operation or through the remote interface operation. The locations of the buttons are highlighted in **Figure 2-2**.

Front Panel Operation

1. Connect the test leads to the terminals on the front panel. Connect the reference signal to the SENSE HI and LO terminals. Then connect the SENSE LO to the INPUT LO terminal.
2. Press DCV button to select DC voltage measurement.
3. Press CONFIG, and then use ◀ and ▶ buttons to locate "RATIO" option.
4. Press ENTER to select it.
5. Connect test leads from the "INPUT HI & LO" and the "SENSE HI & LO" to your source signal and observe readings.

※ Note: The limit of RATIO REF input is 1.2V.

※ Note: To turn off this function, please press one of the measurement function buttons.

※ Note: RAT annunciator will lit when Ratio measurement is on.

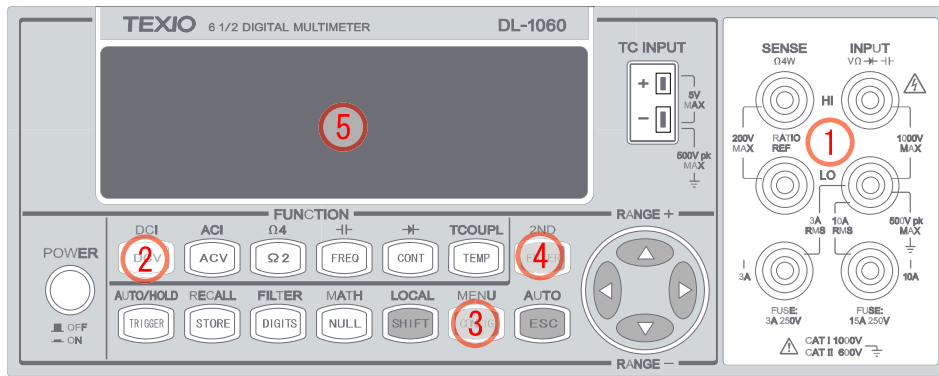

Figure 2-2

Remote Interface Operation

Use the following command to make a RATIO measurement.

CONFigure:VOLTage:DC:RATIo

{<range>|MIN|MAX|DEF},{<resolution>|MIN|MAX|DEF}

2.3 Current Measurements (DC & AC)

The ranges for DC current measurements in DL-1060 are 10mA, 100mA, 1A, 3A and 10A. For AC current measurements, the range is 1A with a sensitivity of 1 μ A to 10A AC-Coupled T-RMS with a sensitivity of 10 μ A. **Figure 2-3** shows you how to measure DC/AC currents in DL-1060.



To avoid damaging the fuse of current input.

- Under current measurements, the input source below 3A or between 3A and 10A will be measured only through the 3A/10A and LO input connectors.
- Ensure the test leads are correctly connected to the DMM current inputs.
- It's important to prevent the internal fuse damage from abusing source over 3 A on the 3A input connector or over 10 A on the 10 Amp connector.
- The measured values will be incorrect under the following conditions.
 1. At 3A terminal, Range: 10 A, Input Source: 3 A
 2. At 10A terminal, Range: 3 A, Input Source: 3 A
- Please do not input the current to both 3A and 10A terminals simultaneously.
- To eliminate the thermal EMFs due to the differences between two metals, use copper leads to connect your source signal to the meter.

How to measure current

1. Connect the test leads to the terminals on the front panel.
2. Set RESOLUTION of DCI (refer to 3.1.3 Resolution & NPLC Setting), BANDWIDTH of ACI (refer to 3.1.2.1 **AC Filter**) or skip this step if default is to be used.
3. Press SHIFT+DCV (or SHIFT+ACV) buttons for DCI (or ACI) measurement.
4. Select the auto-range function by pressing SHIFT + ESC buttons on the front panel or use Δ and ∇ buttons to manually select a desired range.
5. Connect test leads to your source signal and observe readings shown on the display. If the input signal is greater than the allowed range, an overflow message "OVLD" will be displayed.

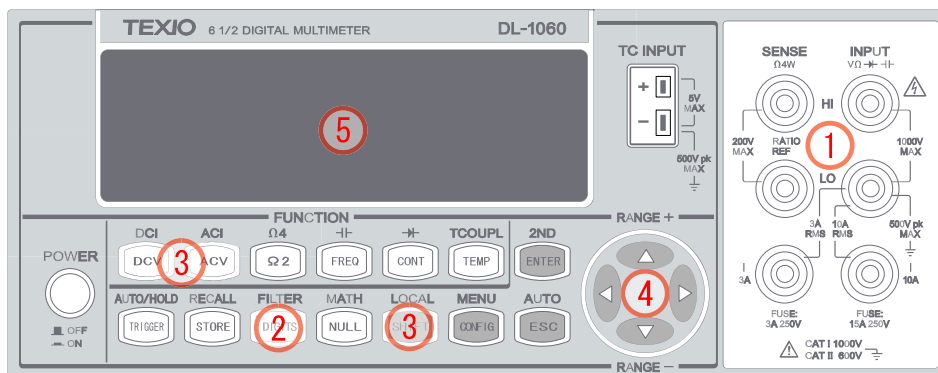

Figure 2-3

2.4 Resistance Measurements (2 & 4-wire)

The ranges for resistance measurement are 100 Ω , 1K Ω , 10k Ω , 100k Ω , 1M Ω , 10M Ω , and 100M Ω , with a sensitivity of 100 $\mu\Omega$ (at 100 Ω range.) There are two modes for measuring the resistance: 2-wire mode as shown in **Figure 2-4** and 4-wire mode as shown in **Figure 2-5**. With 4-wire mode, the test current is measured from the test resistance through one pair of the test leads, and the test voltage across the resistance under test is measured from another set of the test leads. As a result, the 4-wire mode is more accurate for low resistance measurements. The trade off is the longer settling time for 4-wire mode.

How to measure resistance

1. Connect the test leads to the terminals as shown in **Figure 2-4** (2-wire) or **Figure 2-5** (4-wire).
2. Set RESOLUTION (refer to 3.1.3 Resolution & NPLC Setting) or skip this step to use the default setting.
3. Press $\Omega 2$ button for 2-wire measurement or SHIFT+ $\Omega 2$ buttons for 4-wire measurement.
4. Select the auto-range function by pressing SHIFT+ESC button on the front panel or use Δ and ∇ buttons to manually select the desired range.
5. Connect test leads to your source signal and observe readings shown on the display. If the input signal is greater than the allowed range, an overflow message "OVLd" will be displayed.

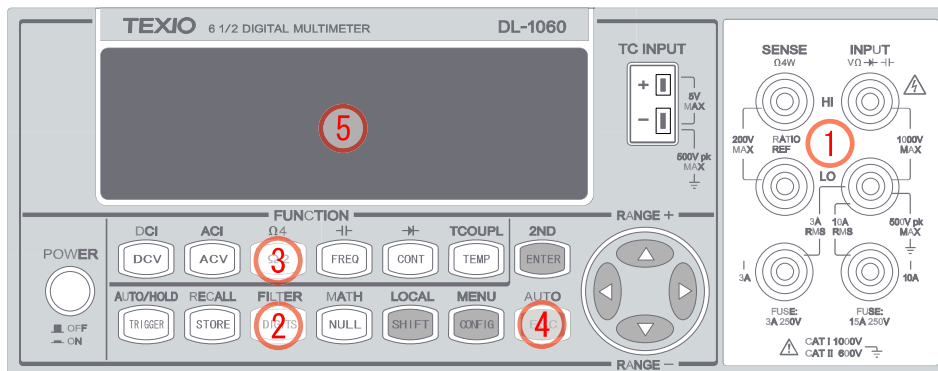

Figure 2-4

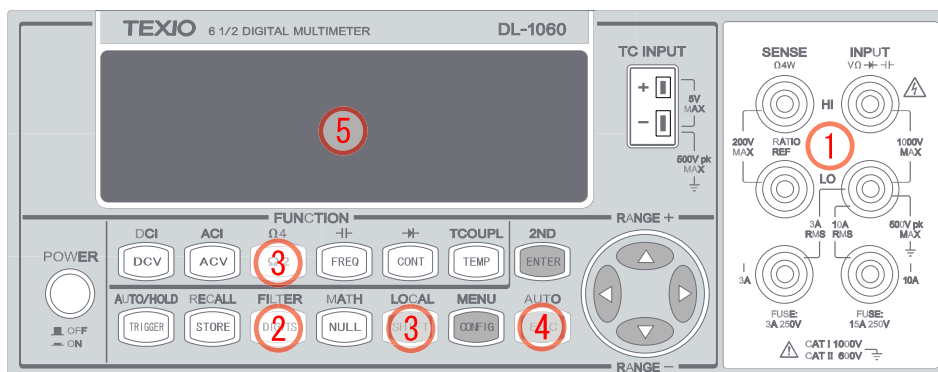

Figure 2-5

※ Note: Ensure the chassis ground is leaded to the ground before measurement in order to prevent the measuring deviation.

2.5 Frequency & Period Measurements

DL-1060 uses an on-board counter with 25MHz to measure the frequency / period. The measurement band is from 3Hz to 300kHz (or 333 ms to 3.3 μ s) and the measurement voltages range from 100mV to 750 V in AC. The range default setting is auto-range.



The maximum input allowed is 750V. Applying excess voltage may damage your meter.

How to measure frequency

1. Connect the test leads to the terminals on the front panel as shown in **Figure 2-6**.
2. Set RESOLUTION (refer to 3.1.3 Resolutin & NPLC Setting) or skip this step to use the default setting.
3. Press **FREQ** button for frequency measurement.
4. Press **CONFIG** button and use \triangleleft and \triangleright buttons to locate the "FREQ" option. Press **ENTER** to select Frequency measurement.
5. Select the auto-range function by pressing **AUTO** button on the front panel or use \triangle and ∇ buttons to manually select the desired range.
6. Connect test leads to your source signal and observe readings shown on the display. If the input signal voltage is beyond the allowed range, an overflow message "VAC OVLD" will be displayed.

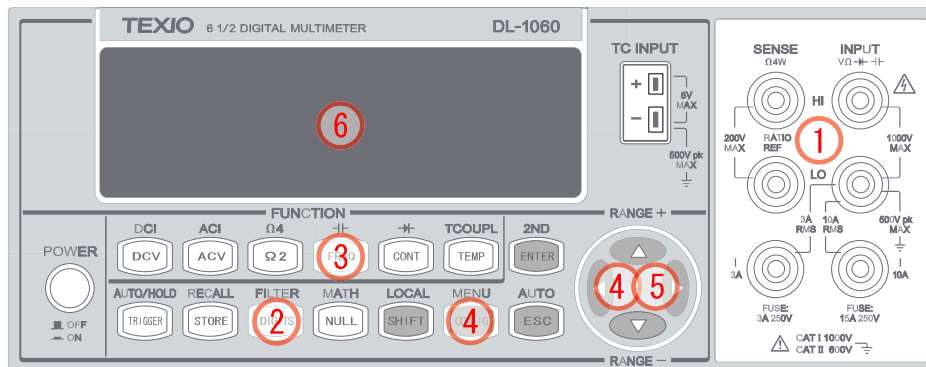

Figure 2-6

How to measure period

1. Connect the test leads to the terminals on the front panel as shown in **Figure 2-7**.
2. Set RESOLUTION (refer to 3.1.3 Resolution & NPLC Setting) or skip this step to use the default setting.
3. Press **FREQ** button for frequency measurement, and then press **CONFIG** button.
4. use **◀** and **▶** buttons to locate "PERIOD". Press **ENTER** to switch the frequency measurement to period measurement.
5. Select the auto-range function by pressing **AUTO** button on the front panel or use **△** and **▽** buttons to manually select the desired range.
6. Connect test leads to your source signal and observe readings shown on the display. If the input signal voltage is beyond the allowed range, an overflow message "VAC OVLD" will be displayed.

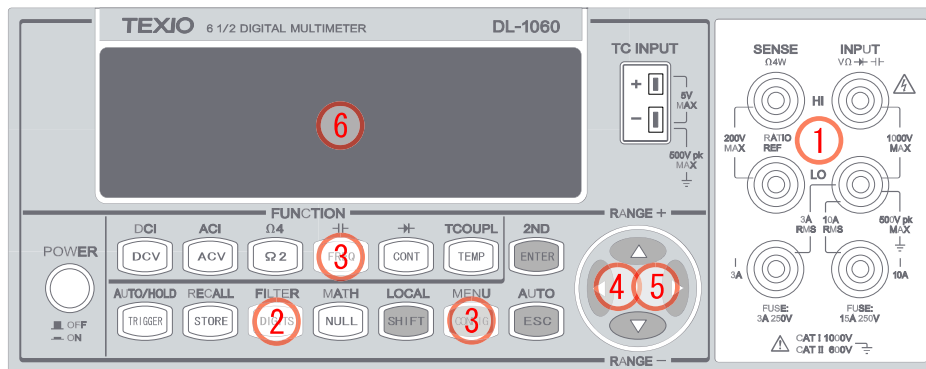

Figure 2-7

2.6 Continuity Measurements

DL-1060 uses 1k Ω range for the continuity measurement. The meter beeps when the test resistance is less than the threshold resistance. The default threshold resistance is 10 Ω , but user can set the threshold resistance to anything between 1 Ω and 1k Ω . The resistance value set by user is stored in a volatile memory and will be cleared after the meter has been turned off. The source current for the continuity measurement is 1mA.



The maximum input voltage allowed is 1000 V (peak). Applying excess voltage may damage the meter and cause unpredictable hazards.

How to measure the continuity

1. Connect the test leads to the terminals on the front panel as shown in **Figure 2-8**.
2. Connect test leads to your source signal.
3. Press CONT button.
4. Set RESOLUTION (refer to 3.1.3 Resolution & NPLC Setting) or skip this step to use the default setting.
5. The result will be shown on the display automatically. Meter “beeps” when measured resistance value is lower than threshold value.

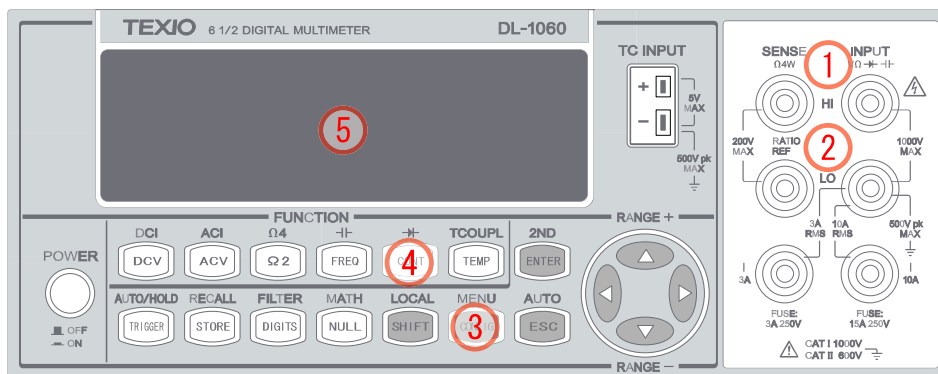

Figure 2-8

2.7 Diode Measurements

DL-1060 uses a current source of 1 mA for diode testing. The maximum resolution is 10 μ V on a fixed range of 1 V DC. The default threshold voltage is fixed between 0.3 and 0.8 volts and the reading rate is fixed at 0.1 PLC (The voltage bound is adjustable from 0.01V up to 1.2V.). The meter beeps when the diode measured value is in the range.



The positive end of the diode should be connected to HI of the input terminals, and the negative end to LO.

How to measure diode

1. Connect the diode to the terminals. For forward bias, connect the probe from input terminal "HI" to the positive end of the diode, and connect the probe from input terminal "LO" to the negative end of the diode as shown in **Figure 2-9**.
2. Press SHIFT + CONT () buttons to select the diode testing function.
3. Set voltage bound by pressing SHIFT+CONT buttons and then pressing CONFIG. When ready, press ENTER. (Or skip this step to use the default voltage bound.)
4. Observe and take readings on the display.

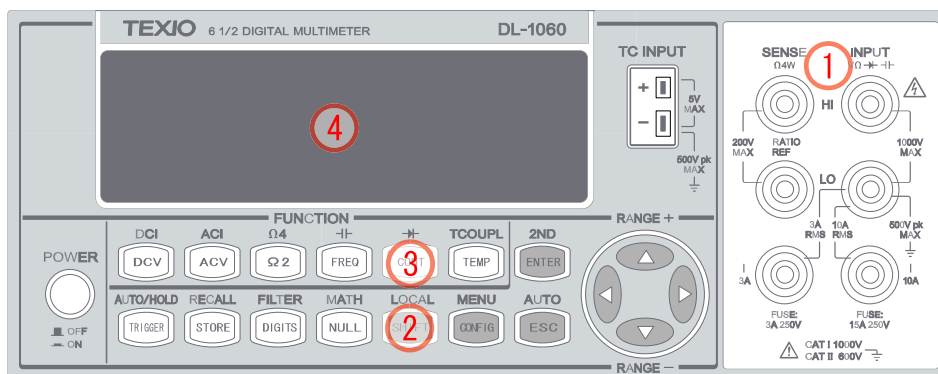

Figure 2-9

2.8 Temperature Measurements

DL-1060 supports thermocouples and resistance temperature detector (RTD) types of probes. For thermocouples, DL-1060 supports 9 types: E, J, K, N, R, S, B, T, and C. Please refer to **Table 2-1** for their temperature ranges. Be sure that the temperature function is configured for the right sensor type before making measurements (Refer to 3.1.8 **Sensor Selection** for how to make the sensor configuration).

In general, RTDs have a better accuracy and long-term stability than thermocouples. The default RTD type in DL-1060 is PT100 and the thermocouple is type K.

Table 2-1

<i>Sensor Type</i>	<i>Temperature Range(°C)</i>	<i>Temperature Range(°F)</i>
E	-250 to1000	-418 to 1832
J	-210 to1200	-346 to 2192
K	-200 to 1372	-328 to 2501.6
N	-200 to1300	-518 to 2372
R	0 to 1767	32 to 3212.6
S	0 to 1767	32 to 3212.6
B	600 to 1820	1112 to 3308
T	-250 to 400	-418 to 752
C	0 to 2316	32 to 4200.8
RTD (PT 100)	-200 to 850	-392 to 1562

2.8.1 Thermocouple Measurements

Connect the thermocouple to the TC INPUT jack on the front panel. The difference between each type is subject to sensors.

How to measure thermocouple

1. To measure thermocouple must be via a purposive sensor as shown in **Figure 2-9**.
2. Press SHIFT + TEMP buttons to select thermocouple measurement.
3. Configure the thermocouple type by using the CONFIG button (refer to 3.1.8) or skip this step to use the default settings.
4. Observe and take readings on the display.

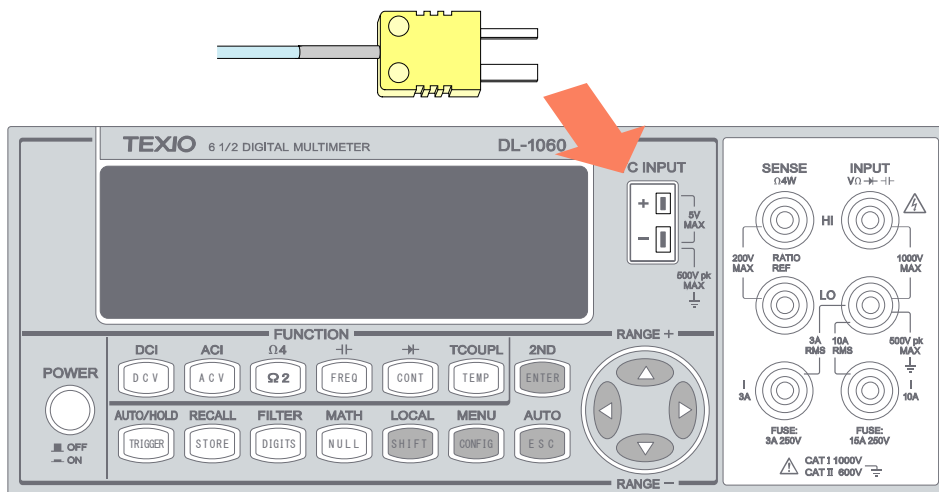

Figure 2-9

2.8.2 RTD Measurements

There are three kinds of temperature measurements with RTDs: 2-wire, 3-wire and 4-wire measurements. You will find connection instructions and measuring procedures in the following sections. The source current for the RTD measurement is 1 mA.

2.8.2.1 2-Wire RTD Measurements

How to measure temperature with 2-Wire RTD

The following **Figure 2-10** shows theory diagram of 2-Wire RTD measurement.

1. Insert a specified adapter into the front terminals.
2. Press TEMP button.
3. Configure sensor type and unit by using the CONFIG button (refer to 3.1.8 **Sensor Selection**) or skip this step to use the default settings.
4. Observe and take readings on the display.

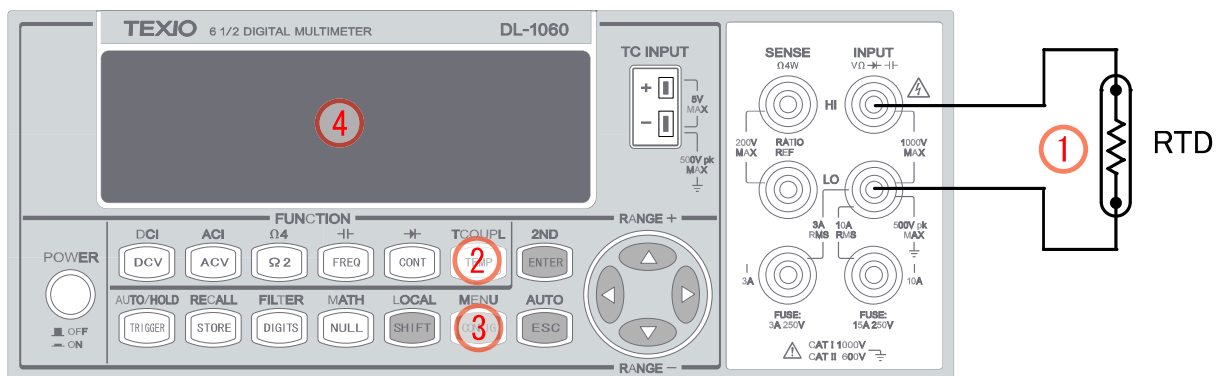

Figure 2-10

2.8.2.2 3-Wire RTD Measurements

How to measure temperature with 3-Wire RTD

The following **Figure 2-11** shows theory diagram of 3-Wire RTD measurement.

1. Insert a specified adapter into the front terminals, and connect the low thermal patch leads to the adapter.
2. Press TEMP button.
3. Configure sensor type as you would be with 4-wire RTD and unit by using the CONFIG button (refer to 3.1.8 **Sensor Selection**) or skip this step to use the default settings.
4. Observe and take readings on the display.

※ Note: When users do the 3-wire RTD measurement the input LO and sense LO have to be connected in short condition.

※ Note: "Source" means RTD Probe or RTD Simulator.

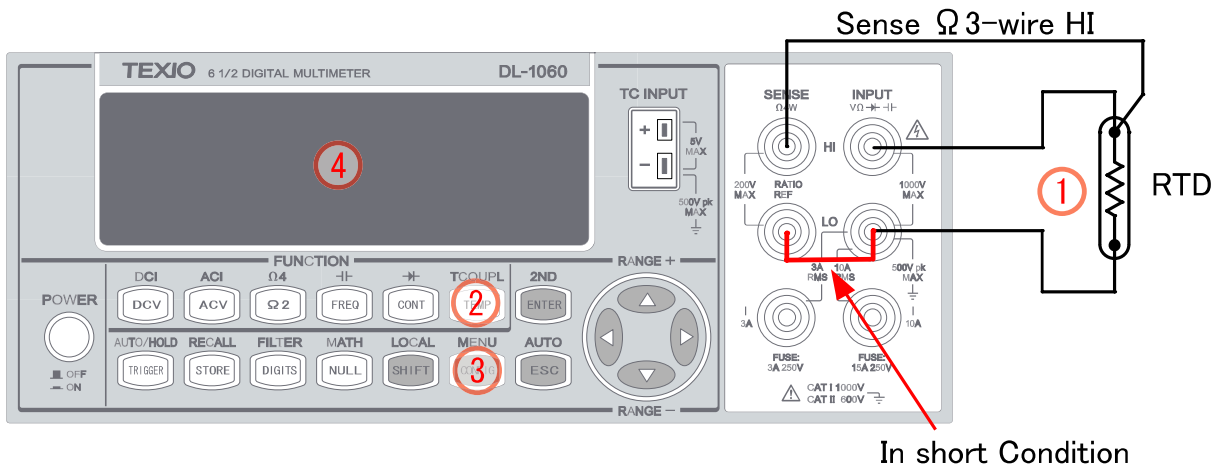

Figure 2-11

2.8.2.3 4-Wire RTD Measurements

How to measure temperature with 4-Wire RTD

The following **Figure 2-12** shows theory diagram of 4-Wire RTD measurement.

1. Insert a specified adapter into the front terminals.
2. Press TEMP button.
3. Configure sensor type and unit by using the CONFIG button (refer to 3.1.8 **Sensor Selection**) or skip this step to use the default settings.
4. Observe and take readings on the display.

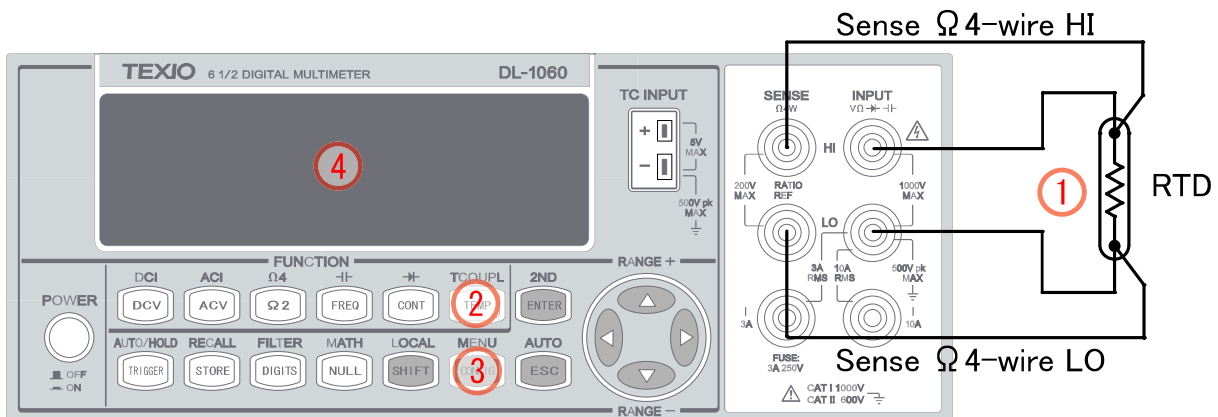

Figure 2-12

2.9 Capacitance Measurements

The ranges for capacitance measurements in DL-1060 is 1 nF, 10 nF, 100 nF, 1 μ F, 10 μ F, 100 μ F, 1000 μ F and 10000 μ F. The default for "range" is auto-range.

How to measure capacitance

1. Connect the test leads to the terminals on the front panel as shown in **Figure 2-13**.
2. Press SHIFT + FREQ to select capacitance measurement function.
3. Select the auto-range function by pressing SHIFT+ESC button on the front panel or use Δ and ∇ buttons to manually select the desired range.
4. Observe and take readings on the display.

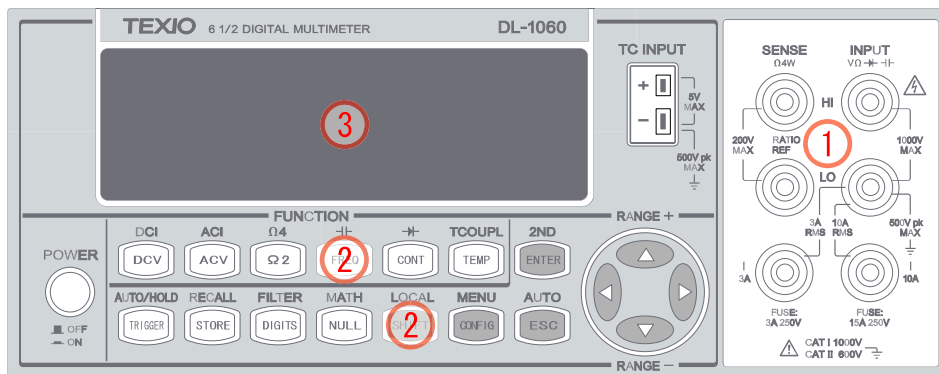

Figure 2-13

2.10 2ND Measurement

DL-1060 provides a secondary measurement function as users make a primary measurement. By using 2nd function, users are able to make two measurements at the same time. The **Table 2-2** below shows the available measurement functions for each primary measurement on DL-1060.

Table 2-2
(Available 2ND functions on DL-1060)

2ND Prim.	DCV	DCI	2W	4W	ACV	ACI	FREQ	PER	FREQ_C	PER_C	CAP	TEMP	TCO
DCV	—	△	—	—	○	—	○	○	—	—	—	—	○
DCI	△	—	—	—	△	○	○	○	○	○	—	—	○
2W	—	—	—	—	—	—	—	—	—	—	—	—	○
4W	—	—	—	—	—	—	—	—	—	—	—	—	○
ACV	○	△	—	—	—	—	○	○	—	—	—	—	○
ACI	—	○	—	—	—	—	—	—	○	○	—	—	○
FREQ	○	○	—	—	○	—	—	○	—	—	—	—	○
PER	○	○	—	—	○	—	—	—	—	—	—	—	○
FREQ_C	—	○	—	—	—	○	—	—	—	○	—	—	○
PER_C	—	○	—	—	—	○	—	—	○	—	—	—	○
CAP	—	—	—	—	—	—	—	—	—	—	—	—	○
TEMP	—	—	—	—	—	—	—	—	—	—	—	—	○
TCO	○	○	○	○	○	○	○	○	○	○	○	○	—

○: Available

△: Not covered

—: Unavailable

- ※ △: This symbol indicates that the measured value is not covered by the specifications.
- ※ Note: To simultaneously measure the DCI & DCV from the same input source, you have to use three leads. The voltage and current measurements must share the same common lead at the LO terminal. However, this application will cause an inaccurate measurement due to the leads combining with a small amount of internal resistance in the DMM and forming an IR which directly and annoyingly affects the measurement. For instance, 30 mΩ of lead resistance will cause approximate 90 mV error at 3 A.



When executing the 2nd function with voltage and current measurements, do not connect the different voltage at the LO terminal. Connecting the short condition may damage your meter and EUT (Equipment Under TEST), or cause possible fire or personal injury.

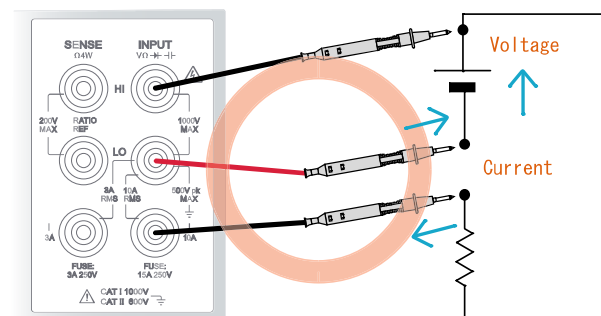
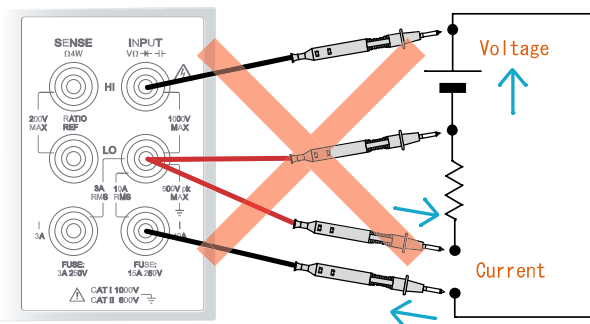

How to use 2ND measurement

1. Press one of the measurement function keys to select a primary measurement.
2. Press SHIFT+ENTER to enter 2ND submenu.
3. Use ◀ or ▶ button to locate a desired secondary measurement, and press ENTER to select it.
4. Use ◀ or ▶ button to locate a desired secondary configuration, and then press ENTER to select it. If you need to set another configuration, repeat the operation from Pressing SHIFT+ENTER.
5. Observe and take readings on the display. The upper row display is the primary measurement and the lower row display is the secondary measurement.

※ Note: To execute the 2nd function with DCI, applying the range at 1A or up.

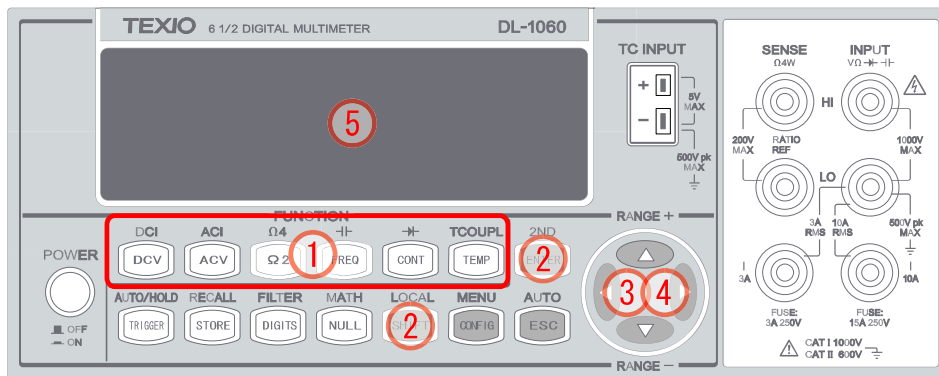

Figure 2-14



Remote Interface Operation

To set 2nd through the remote interface, use the following commands:

These commands are used for selecting two functions on the 2nd applications. 1 stands for the selected function which will act on the main display. 2 stands for the selected function which will act on the secondary display.

[SENSe:]FUNCTION "<function>"

For example:

FUNCTION[1/2] "VOLTage:DC"

FUNCTION[1/2] "VOLTage:AC"

FUNCTION[1/2] "CURREnt:DC"

FUNCTION[1/2] "CURREnt:AC"

FUNCTION[1/2] "FREQuency"

FUNCTION[1/2] "PERiod"

FUNCTION[1/2] "FREQuency:CURR"

FUNCTION[1/2] "PERiod:CURR"

FUNCTION[1/2] "RESistance"

FUNCTION[1/2] "FRESistance"

FUNCTION[1/2] "CAPacitance"

FUNCTION[1/2] "TEMPerature"

FUNCTION[1/2] "TCouple"

FUNCTION[1/2] "NONE"

FUNCTION[1/2]?

When enabling the 2nd function, you can still set the range and NPLC individually. The setting procedures are as usual.

To set the range and NPLC through the remote interface, use the following commands:

[SENSe:]<function>:RANGe {<range> | MINimum | MAXimum}

[SENSe:]<function>:RANGe:AUTO {OFF | ON}

[SENSe:]<function>:NPLCycles {0.001|0.006|0.02|0.06|0.2|0.6|1|2|10|100|MIN|MAX}

To read and fetch values from the DMM, use the following commands:

READ[1|2]?

FETCH[1|2]?

For example:

FUNC2 "VOLT:DC" (Set secondary function to DCV)

READ2? (Take secondary reading)

READ? (Take readings; SD.DDDDDDDDESDD, SD.DDDDDDDDESDD <nl>)

The following error codes might occur when corresponding function or range is not enabled or mismatch.

- **-243 Second function invalid**

It means Secondary function is not enabled

- **223 2nd function mismatch**

It means function/2nd func mismatch.

- **225 Function/range mismatch**

It means function/range mismatch.

3 Front Panel Operations

This chapter contains information about how to change the parameters and settings for your measurements and all the details about each feature and function.

3.1 Measurement Configuration

The following information will guide you through ways to configure measurement functions. It provides you the flexibility to change any parameter in any measurement function when needed, including ADC setting, filter, resolution setting (digits), threshold resistance (continuity), range (manual & auto), rate (integration time), sensor type for temperature measurements and remote interface selection.

3.1.1 Set ADC (Auto Zero)

Zero

The purpose of Auto Zero function is to minimize the offset influence on your measurements. When Auto Zero is enabled, DL-1060 takes the input signal reading as a base value and then internally disconnects the input signal, and takes a offset reading (a null offset). It then subtracts the offset from the base to get an accurate measurement.

$$\text{Displayed reading} = \text{Base value (input signal)} - \text{Offset value}$$

When the Auto Zero is enabled the meter takes an offset reading for each subsequent measurement. However, when Auto Zero is disabled, the meter only takes one offset reading each time when you change the function settings. User can set "PERIOD" to change the time interval for taking an offset reading.

Defaults

The default settings for Auto Zero is enabled. The user selected values for Auto Zero are stored in a volatile memory and the default settings will be restored when the meter is power-off.

How to set Auto Zero

The following steps show how to set Auto Zero directly through the front panel. Be aware that Auto Zero setting is always affected by the resolution setting. Whenever the resolution is altered, Auto Zero may be changed accordingly. The relation between resolution and Auto Zero is shown in **Table 3-1**. You can change the Auto Zero setting through the front panel or through the remote interface operation.

Front Panel Operation

1. Press SHIFT+CONFIG buttons as shown in **Figure 3-1**.
2. Use ◀ and ▶ buttons to toggle SET ADC + ENTER > AUTO ZERO + ENTER > ON/OFF + ENTER.

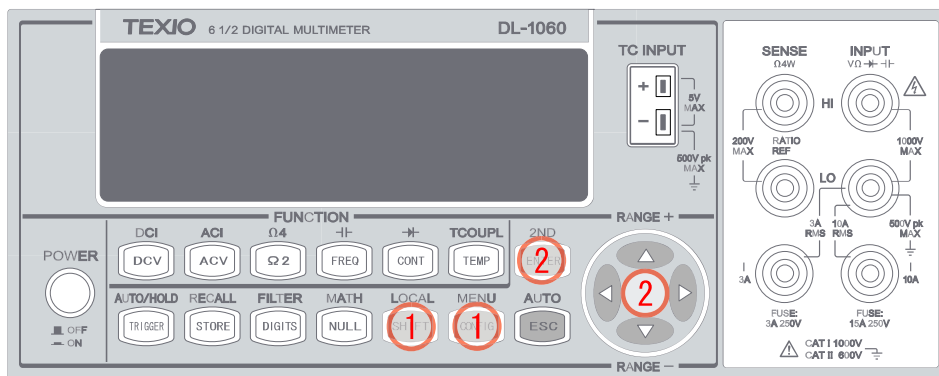

Figure 3-1

Table 3-1

<i>Resolution</i>	<i>Auto Zero</i>	<i>Integration Time(PLC)</i>
Fast 4 ½ digits	Off	0.001
Slow 4 ½ digits	On	0.006
Fast 4 ½ digits	Off	0.02
Slow 4 ½ digits	On	0.06
Fast 5 ½ digits	On	0.2
Slow 5 ½ digits	On	0.6
Slow 5 ½ digits	On	1
Slow 5 ½ digits	On	2
Slow 6 ½ digits	On	10
Slow 6 ½ digits	On	100

※Note:To change resolution, refer to Section:3.1.3 Resolution & NPLC Setting in this chapter.

Remote Interface Operation

To set Auto Zero through the remote interface, use the following commands:

SENSe:ZERO:AUTO {OFF|ONCE|ON}

The OFF and ONCE parameters have a similar effect. Auto Zero OFF doesn't issue a new offset measurement. However, Auto Zero ONCE issues an immediate offset measurement.

3.1.2 Filter

Filter is used to remove noises in measurement readings. DL-1060 is equipped with two types of filters: AC filter and digital filter. AC filter is for AC measurements only. It also affects the speed of the multimeter to yield a measurement reading. Digital filter further stabilizes the measurement readings by averaging. Both filters are described in detail in the subsequent sections respectively.

3.1.2.1 AC Filter (AC only)

Definition:

You can refer to **Table 3-2** to set the bandwidth. User is allowed to set the bandwidth for selecting one of the three AC filters (Slow, Medium and Fast), in order to achieve either higher accuracy in low frequency measurements or faster AC settling time.

Defaults

The factory default is 20Hz (Medium). You can select your filter type as you wish when setting bandwidth value. The defined selection is stored in a volatile memory and the default setting will be restored when the meter is power-off.

Table 3-2

<i>Bandwidth</i>	<i>AC Filter</i>	<i>Remote Trigger Delay (seconds per reading)</i>
3 Hz to 300 KHz	Slow	7
20 Hz to 300 KHz	Medium	1
200 Hz to 300 KHz	Fast	0.1

How to set AC Filter in AC measurements:

You can set the AC Filter either through the front panel operation or through the

remote interface operation.

Front Panel Operation

1. Press ACV button and then CONFIG buttons as shown in **Figure 3-2**.
2. Use ◀ and ▶ buttons to locate "BAND WIDTH" submenu, and then press ENTER to select it. (There are three options: 3Hz, 20Hz and 200Hz.)

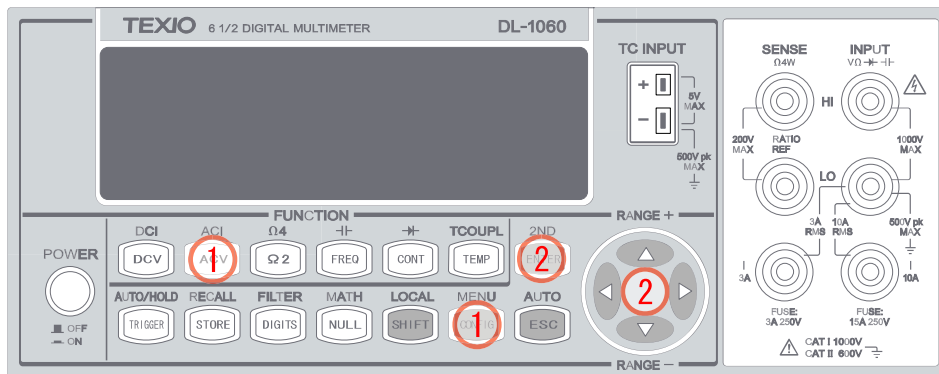

Figure 3-2

Remote Interface Operation

From your PC terminal, use the following command to specify the filter type:

DETECTOR:BANDwidth {3|20|200|MIN|MAX}

3.1.2.2 Digital Filter

Definition:

DL-1060 uses an averaging digital filter to yield a reading for display from a specified number of measurement readings in the past. The past measurement readings are stored in a stack of memory. The number may be in the range of 2 to 100. You may select one of the two modes of digital filter operations: Moving Average and Repeating Average.

The moving average filter puts the specified number of reading conversions in a first-in, first-out order. The very first measurement reading simply fills up the stack. To yield a reading for display, the filter produces an average of the stacked measurement readings every time when a new measurement reading is available and replaces the oldest reading in the stack. In the repeating average mode, the multimeter waits for the measurement reading stack to fill up and then take an average to produce a reading for display. It then flushes the stack and starts over with an empty stack. Consequently, the repeating digital filter yields one reading for display every specified number of measurement readings.

※ Note: Digital filter is not available for diode, continuity, frequency and period measurements.

Default

The digital filter is enabled and is in moving average mode with 10 readings by default.

Front Panel Operation

How to enable/disable digital filter

1. Press SHIFT+DIGITS buttons to switch to the digital filter function as shown in **Figure 3-3**.
2. Use ◀ and ▶ buttons to toggle between options.
3. Press ENTER on “OFF” to disable the filter. Or Press ENTER on the other two options to enable it.
4. Press RUN to start The “FILT” annunciator lights up when filter is enabled.

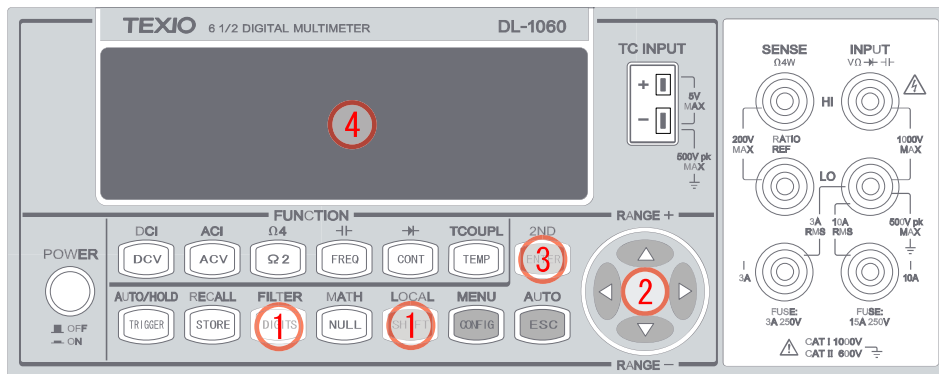

Figure 3-3

How to configure digital filter:

You can configure the digital Filter either through the front panel operation or through the remote interface operation.

For MODE setting:

1. Press SHIFT+DIGITS buttons and then use ◀ and ▶ buttons to toggle between “OFF”, “MOVING AVG” and “REPEAT AVG” as shown in **Figure 3-4**.
2. Press ENTER on your selection.

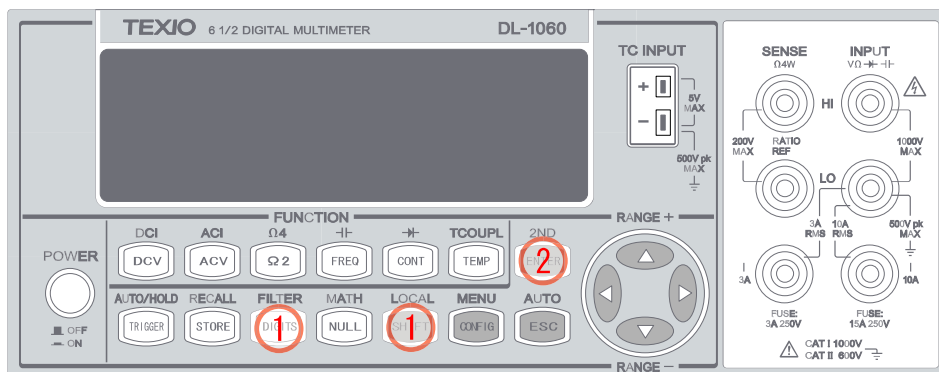

Figure 3-4

For READINGS setting:

1. After enabling the filter (see above), use ◀ and ▶ buttons to locate “READINGS”. Press ENTER to select it. Use ◀ and ▶ to move through the digits and ▲ and ▼ buttons to increase or decrease the number to a desired value (from 2 to 100). Press ENTER to set the value. Press ENTER in “RUN” to start reading as shown in **Figure 3-5**.

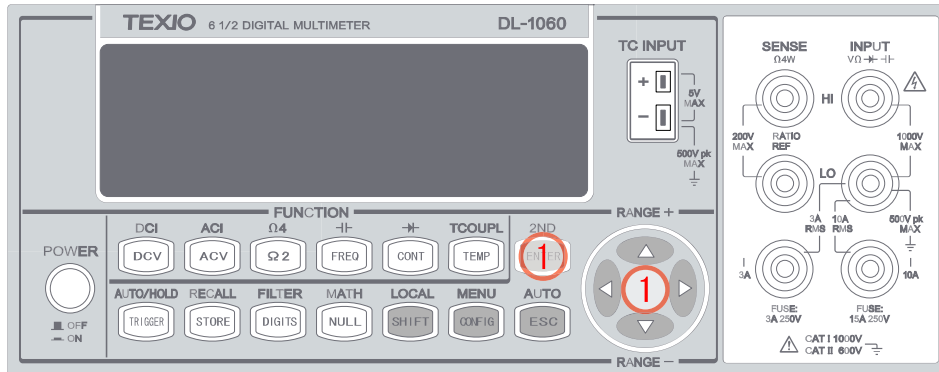

Figure 3-5

Remote Interface Operation

Use the following commands to set your digital filter:

- SENSe:AVERage:TCONtrol {MOVing|REPeat}**
- SENSe:AVERage:TCONtrol?**
- SENSe:AVERage:COUnT {<value>|MINimum|MAXimum}**
- SENSe:AVERage:COUnT? [MINimum|MAXimum]**
- SENSe:AVERage:STATe {OFF|ON}**
- SENSe:AVERage:STATe?**

3.1.3 Resolution & NPLC Setting

Definition

Resolution is the number of digits a multimeter can measure. You can select the resolution for a specific measurement. The choices for the resolution setting are: 4 1/2, 5 1/2, 6 1/2. For a faster measurement, you can select 0.001 PLC. For a stable, higher accuracy measurement, 100PLC is suggested to select. However, the NPLC setting is used for DCV, DCI, $\Omega 2$ & $\Omega 4$ functions only. The **Table 4-1** is the relationship between the resolution and the integration time. The lowest PLC on each digit range is the rapidest selection, such as 0.001 PLC at 4 1/2 digits, 0.2 PLC at 5 1/2 digits and 10 PLC at 6 1/2 digits.

In addition, the resolution setting applies to all math operations under the selected measurement function. The selected value is stored in a volatile memory and the setting is only valid for the present measurement functions. You can select different resolution for different measurement functions.

Default

The default value for the resolution is 6 1/2 digits with 10 PLC and the default value will be restored when the meter has been turned off or after a remote interface reset. The manual selected value for the resolution setting is stored in a volatile memory and the setting is only valid for the present measurement function. Please refer to **Table 1-1** on page 16.

How to set the resolution

The resolution can be set either through the front panel or the remote interface operation.

Front Panel Operation

There are two ways to set the resolution. The locations of the buttons are shown with red rectangle frames in **Figure 3-6** and **Figure 3-7**.

Way One:

1. First select your desired measurement function by pressing one of the function buttons located on the first row of your meter's front panel.
2. Press DIGITS button to select your desired resolution for your measurement.

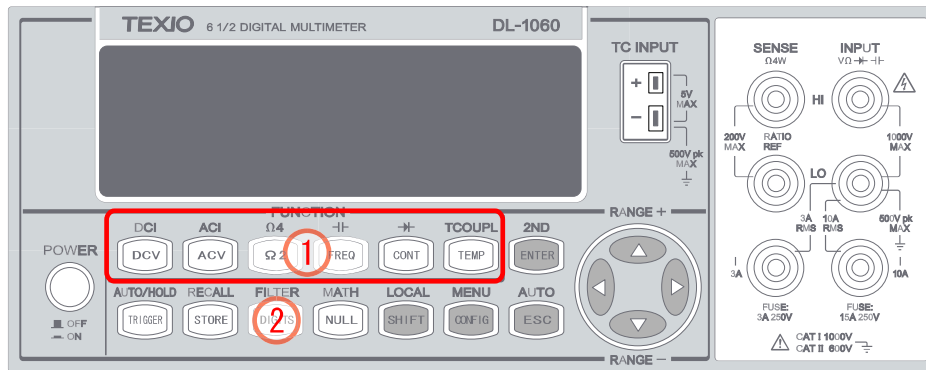

Figure 3-6

※ Note: When using the Way One to set the resolution, your options with each press on the same button are 4 1/2, 5 1/2 and 6 1/2. And under the DCV, DCI, Ω2 & Ω4 functions, the NPLC just can be set by pressing CONFIG > NPLC > ENTER > ◀ and ▶ > Target NPLC.

Way Two (for DCV, DCI, Ω2 & Ω4 functions only):

1. Select a desired function within DCV, DCI, Ω2 & Ω4.
2. Do the procedure CONFIG > NPLC > ENTER > ◀ and ▶ > Target NPLC to set NPLC. (Please refer to the **Table 3-1** to set digits.)

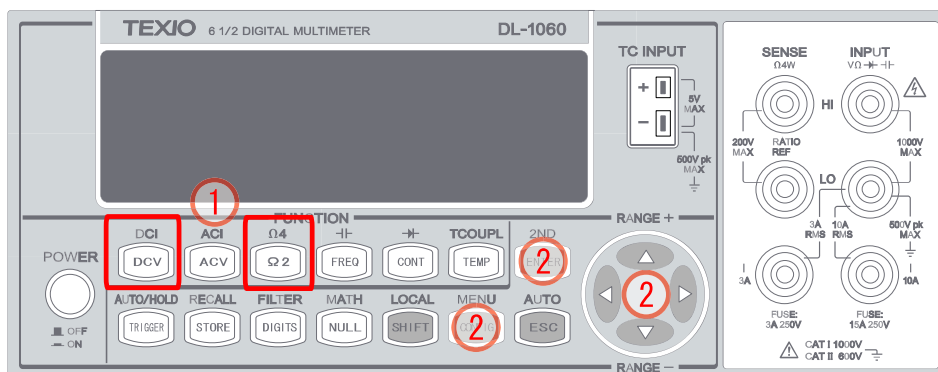

Figure 3-7

Remote Interface Operation

Use the following commands on your PC terminal to set the resolution for your measurement.

CONFigure:<function> <range>,<resolution>

MEASure:<function>? <range>,<resolution>

SENSE:<function>:RESolution <resolution>

You can specify the resolution in the same units as the measurement function, not in number of digits. For instance, specify the resolution in volts and the frequency in hertz. Below are some examples.

- | | |
|------------------------------|---|
| CONF:VOLT:DC 10,0.001 | (4 1/2 digits on the 10Vdc range) |
| MEAS:CURR:AC? 1,1E-6 | (6 1/2 digits on the 1A range) |
| CONF:FREQ 1kHz,0.1Hz | (1000 Hz input, 0.1Hz resolution) |
| VOLT:AC:RES 0.05 | (50mV resolution on the ac function) |

3.1.4 Threshold Resistance (Continuity)

Definition

When testing continuity, the beeper goes off when the measured resistance is less than the threshold resistance. The threshold resistance can be set to any value between 1Ω and 1000Ω .

Default

The factory default for continuity threshold resistance is 10Ω . Your selection is stored in a volatile memory and the default value will be restored after the meter has been turned off.

How to set the threshold resistance

You can change the threshold resistance only through the front panel as shown in **Figure 3-8**.

1. Press CONT button and then CONFIG button.
2. Press ENTER button to access the threshold resistance settings.
3. Use \triangleleft and \triangleright buttons to move through the digits and lower or increase the number to your desired value by using \triangle and ∇ buttons.
4. Press ENTER button again to confirm the value.

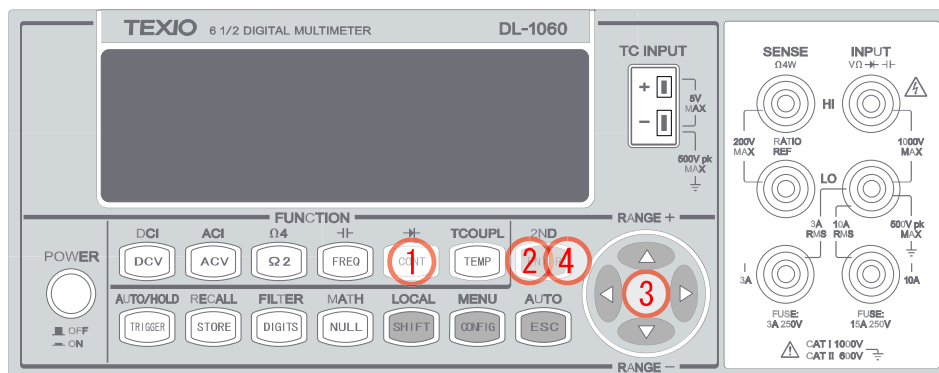

Figure 3-8

3.1.5 Range (Manual & Auto)

Definition

When making measurements except CONT, DIODE, TCOUPL, and Temperature, DL-1060 will automatically choose a range for you, or you can select the appropriate range manually. The difference between auto-range and manual-range is the settling time. Auto-range is a convenient way for you, but manual-range can usually speed up the process.

If the input signal is beyond allowed range, an "OVLd" message will be shown on the display. The threshold of maximum/minimum readings for each range are 120 % of the range for maximum and 10% of the range for minimum.

Default

The default is auto-range. The manual selected range is stored in volatile memory and the default will be restored when the meter is power-off. Please refer to **Table 1-1** on chap. "Factory Default When Power-ON".

How to set the auto/manual range:

You can set the auto/manual range either through the front panel operation as shown in **Figure 3-9** or through the remote interface operation.

Front Panel Operation

1. Choose a measurement function.
2. Press SHIFT + ESC button to select auto-range feature. Or use Δ and ∇ buttons to manually select a range(MAN annunciator will lit when manually selecting a range).

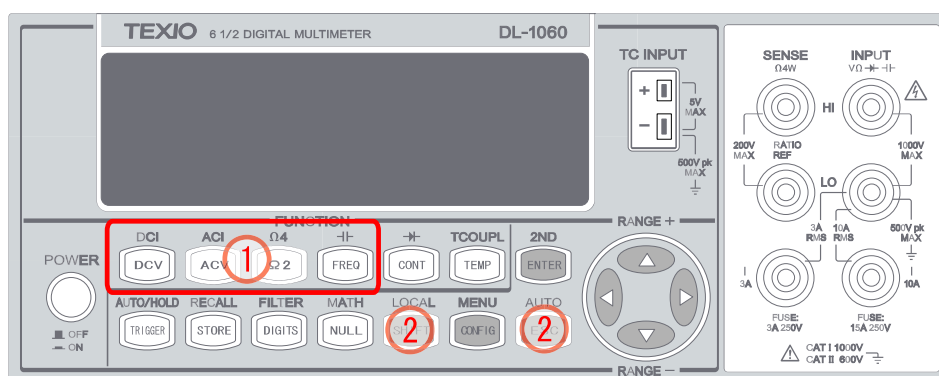

Figure 3-9

Remote Interface Operation

Use the following commands from your PC terminal to set the range:

CONFigure:<function> <range>,<resolution>

MEASure:<function>? <range>,<resolution>
SENSe:<function>:RANGe <range>
SENSe:<function>:RANGe:AUTO {OFF|ON}

3.1.6 Rate (Integration Time)

Definition

Integration time is the period of time the analog-to-digital (A/D) converter takes to sample the input signal. The integration time feature allows user to optimize either the speed or the resolution, as well as the noise rejection and the accuracy of the measurement. The unit of the integration time is in PLC (power line cycles). One PLC for 60 Hz is 16.67 ms, and for 50 Hz is 20 ms.

There are 10 different integration times in DL-1060 for user to select from: 0.001, 0.006, 0.02, 0.06, 0.2, 0.6, 1, 2, 10, and 100 PLC.

Default

For DCV, DCI, and resistance measurement, the default integration time is 1 PLC. The manual selected value is stored in a volatile memory and the default value will be restored when the meter is power-off.

How to set the integration time:

You can set the integration time either through the front panel operation or through the remote interface operation.

Front Panel Operation

Integration time is set indirectly when you select the measurement resolution. Please refer to chapter 3.1.3 for details about how to set resolution or NPLC. **Table 3-1** shows the relationship between the resolution and the integration time.

Remote Interface Operation

Use the following commands on your PC terminal to set the resolution.

CONFigure:< function> <range>, <resolution>
MEASure:< function>? <range>, <resolution>
SENSe:< function>:RESolution <resolution>

Or you can set integration time directly by the following commands.

SENSe:VOLTage:DC:NPLCycles
{0.001|0.006|0.02|0.06|0.2|0.6|1|2|10|100|MINimum|MAXimum}
SENSe:VOLTage:DC:NPLCycles? [MINimum|MAXimum]

SENSe:CURRent:DC:NPLCycles
{0.001|0.006|0.02|0.06|0.2|0.6|1|2|10|100|MINimum|MAXimum}
SENSe:CURRent:DC:NPLCycles? [MINimum|MAXimum]
SENSe:RESistance:NPLCycles
{0.001|0.006|0.02|0.06|0.2|0.6|1|2|10|100|MINimum|MAXimum}
SENSe:RESistance:NPLCycles? [MINimum|MAXimum]
SENSe:FRESistance:NPLCycles
{0.001|0.006|0.02|0.06|0.2|0.6|1|2|10|100|MINimum|MAXimum}
SENSe:FRESistance:NPLCycles? [MINimum|MAXimum]

For frequency and period measurements, aperture time (or gate time) is analogous to integration time, and you can use the following commands to set it. Specify 10 ms (4 1/2 digits), 100 ms (default; 5 1/2 digits), or 1 second (6 1/2 digits).

SENSe:FREQuency:APERture {0.01|0.1|1|MINimum|MAXimum}
SENSe:FREQuency:APERture? [MINimum|MAXimum]
SENSe:PERiod:APERture {0.01|0.1|1|MINimum|MAXimum}
SENSe:PERiod:APERture? [MINimum|MAXimum]

3.1.7 Sensor Selection for Temperature Measurements

The multimeter supports both thermocouple and RTD. User needs to configure the multimeter for the right sensor type before they can make temperature measurements.

RTD

Definition

If you are using RTD, the options are: PT100, D100, F100, PT385, PT3916, user-defined RTD, NTCT and SPRTD. If you need to change the factors that are used to calculate the temperature in RTD, choose user-defined RTD in which you are able to change any factors as you wish. The default factors used are listed in **Table 3-3**:

Table 3-3

<i>Type</i>	<i>Alpha</i>	<i>Beta</i>	<i>Delta</i>	<i>R-zero</i>
PT100	0.003850	0.10863	1.49990	100Ω
D100	0.003920	0.10630	1.49710	100Ω
F100	0.003900	0.11000	1.49589	100Ω
PT385	0.003850	0.11100	1.50700	100Ω
PT3916	0.003916	0.11600	1.50594	100Ω
NTCT	0.003850	0.10863	1.49990	100Ω

Here is the temperature equation that is used to determine the RTD temperature:

When $t < 0^{\circ}C$:

$$R_t = R_0 \left[1 + At + Bt^2 + Ct^3(t - 100) \right]$$

When $0^{\circ}C < t < 630^{\circ}C$:

$$R_t = R_0 (1 + At + Bt^2)$$

Where:

$$A = \alpha \left(1 + \frac{\delta}{100} \right)$$

$$B = -\alpha\delta \cdot 10^{-4}$$

$$C = -\alpha\beta \cdot 10^{-8}$$

If you are using SPRTD(Standard Platinum RTD), select SPRTD and specify the seven coefficients under SPRTD submenu.

The ITS (International Temperature Scale) -90 standard provides two reference equations for Standard Platinum Thermometers covering temperature range from 18.8033K to 1234.93K. However, one SPRTD usually cannot cover the entire range, so the temperature range is broken up into a few subranges. These subranges depend on the calibration point of temperature scale and are based on the melting or triple points of various pure substances. For an exact list of the elements needed and details on RTD calibration, refer to NIST Technical Note 1265 "Guidelines For Realizing the International Temperature Scale of 1990". In each subrange, the calibration constants required for that subrange are listed.

Default

The default sensor type in DL-1060 is PT100.

How to set up RTD

You can set up the RTD configuration either through the front panel operation or through the remote interface operation as shown in **Figure 3-10** or through the remote interface operation.

Front Panel Operation

1. Press TEMP button to select RTD temperature measurement function.
2. Press CONFIG button.
3. Use \triangleleft and \triangleright to locate SENSOR submenu. Press ENTER to select it.
4. Use \triangleleft and \triangleright to locate your sensor type. Press ENTER to select your desired sensor type.

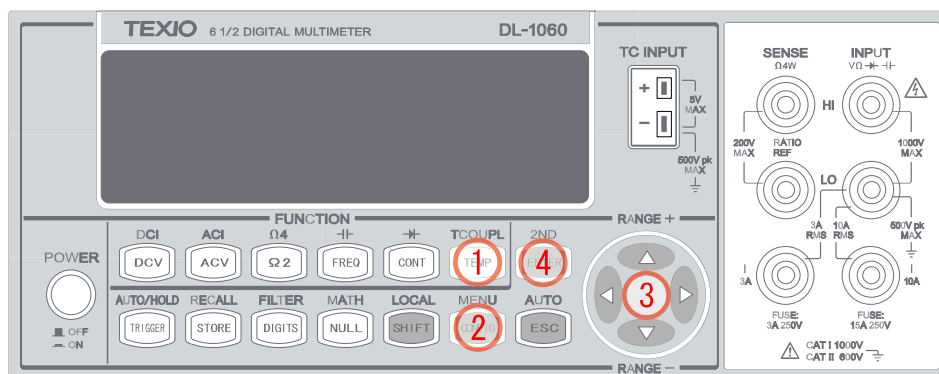

Figure 3-10

Choosing **USER** takes you to a menu where you can specify factors used in the calculation equation to obtain the temperature. Use ◀ and ▶ to move through the digits and △ and ▽ to change the numbers to a desired value. Press ENTER to set the value.

Choosing **SPRTD** takes you to a menu where you can specify the seven coefficients that are used to determine the temperature. Use ◀ and ▶ to move through the digits and △ and ▽ to change the numbers to a desired value. Press ENTER to set the value.

2-wire/4-wire selection

1. Press TEMP button to select RTD temperature measurement function as shown in **Figure 3-11**.
2. Press CONFIG button.
3. Use ◀ and ▶ to locate TRANSDUCER submenu. Press ENTER to select it.
4. Use ◀ and ▶ to locate a desired option. Press ENTER to finish the process.

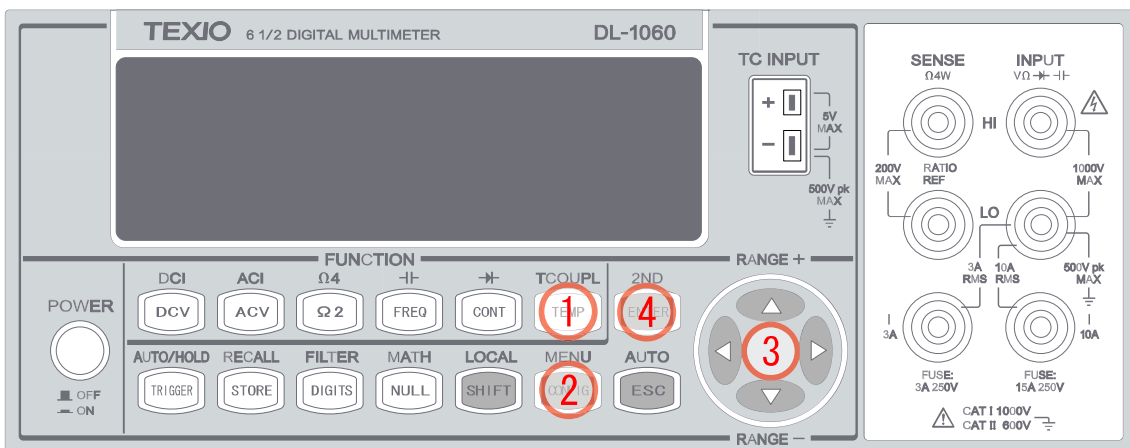

Figure 3-11

Remote Interface Operation

Use the following commands to set up the RTD configuration.

SENSE:TEMPerature:RTD:TYPE{PT100|D100|F100|PT385|PT3916|USER|SPRTD|NTCT}

SENSE:UNIT {Cel|Far|K}

SENSE:UNIT?

SENSE:TEMPerature:RTD:RZERO {<value>|MINimum|MAXimum}

SENSE:TEMPerature:RTD:ALPHA {<value>|MINimum|MAXimum}

SENSE:TEMPerature:RTD:BETA {<value>|MINimum|MAXimum}

SENSE:TEMPerature:RTD:DELTA {<value>|MINimum|MAXimum}

SENSE:TEMPerature:SPRTD:RZERO {<value>|MINimum|MAXimum}

SENSE:TEMPerature:SPRTD:A4 {<value>|MINimum|MAXimum}

SENSE:TEMPerature:SPRTD:B4 {<value>|MINimum|MAXimum}

SENSE:TEMPerature:SPRTD:AX {<value>|MINimum|MAXimum}

SENSE:TEMPerature:SPRTD:BX {<value>|MINimum|MAXimum}

SENSe:TEMPerature:SPRTD:CX {<value>|MINimum|MAXimum}
SENSe:TEMPerature:SPRTD:DX {<value>|MINimum|MAXimum}

Thermocouple

Definition

DL-1060 is built-in cold junction compensation that can improve the accuracy of thermo measurements. If you are using this function, you have to set an adapter type. For example, through the "TYPE" selections you are available to use a specific adapter K, J, R, S, T, E, N, B, or C for temperature measurement.

Perhaps it's not the solution you want according to your application. Pick the next selection RJUNCTION's REAL or RJUNCTION's SIMULATED by the procedure SHIFT > TEMP > CONFIG > RJUNCTION > REAL/SIMULATED. This procedure is not for the settings, but the function execution. Before executing, please go setting REAL or SIMULATED peremeters by the procedure SHIFT > TEMP > CONFIG > SIMULATED/REAL.

What's the difference between the REAL and the SIMULATED? For the REAL, the REAL value is a standard value detected from the present internal equipment, i.e. the value would be frequently influenced and changed at different environments and climates, and it can't be adjusted. For the SIMULATED, the SIMULATED value is a reference value. To use this function, you need to be aware that the temperature value from a certain object is absolute meaningful and accurate, for example 0°C(mixed ice and water). After you well selet the type and matched the correct adaptor, the tested result from the mixed ice and water is 2°C. At this circumstance, you know the real and tested error is 2°C. So the next step is to adjust the default value from 25°C to 23°C. Then your following thermocouple measurements with the simulated function would be accurate.

How to set up thermocouple

You can set up the thermocouple configuration either through the front panel operation or through the remote interface operation.

Front Panel Operation (Unit and Thermocouple configuration)

1. Press SHIFT+ TEMP to choose thermocouple function as shown in **Figure 3-12**
2. Press CONFIG, and then use ◀ and ▶ to toggle between options.
3. To configure unit or thermocouple type, press ENTER on "UNIT" and "TYPE" respectively.

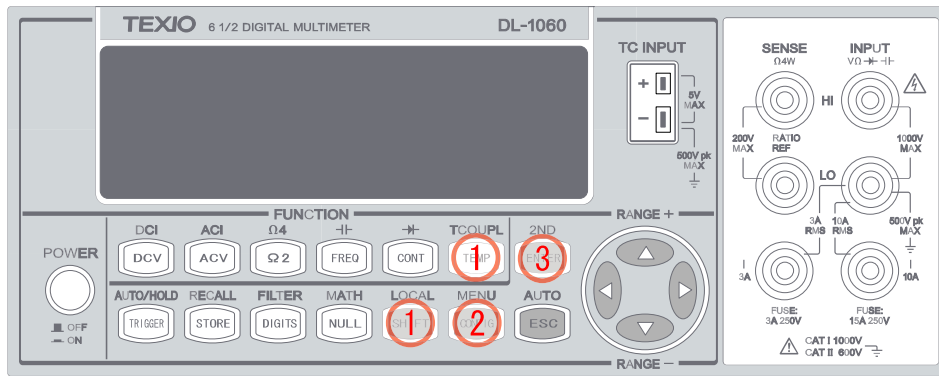

Figure 3-12

Real Temperature Setup

1. Select a type and matched an adaptor correctly as shown in **Figure 3-13**.
2. Press SHIFT+ TEMP to choose thermocouple function.
3. Press CONFIG, and then use ◀ and ▶ to locate "REAL", then press ENTER to check the present temperature.
4. Press ESC to reach the upper layer.
5. Press ◀ and ▶ to locate "RJUNCTION", then do the procedure ENTER > REAL to execute the function.

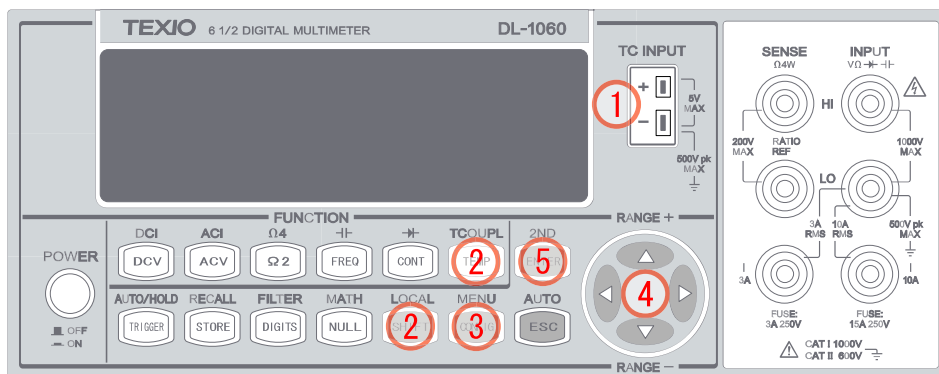

Figure 3-13

Simulated Temperature Setup

1. Select a type and matched an adaptor correctly as shown in **Figure 3-14**.
2. Press SHIFT+ TEMP to choose thermocouple function.
3. Press CONFIG, and then use ◀ and ▶ to locate "RJUNCTION" > "SIMULATED".
4. Use ◀ and ▶ to move through the digits and ▲ and ▼ to increase or decrease the numbers to a desired value.
5. Press ENTER to execute the function.

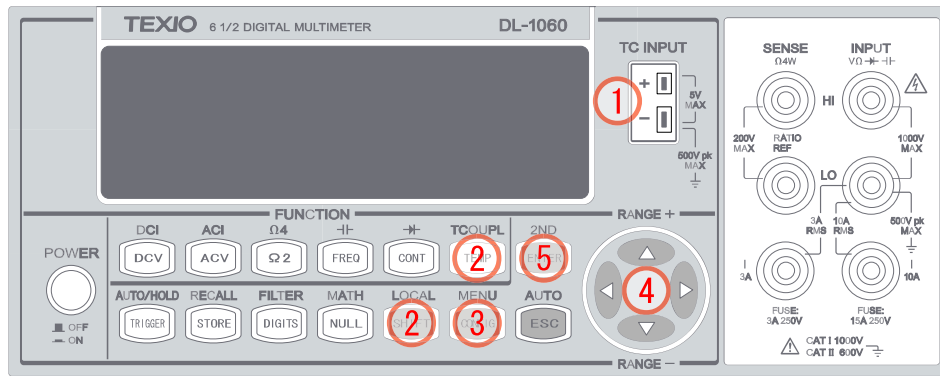

Figure 3-14

Remote Interface Operation

Use the following commands to set up the thermocouple configuration.

SENSe:UNIT {Cel|Far|K}

SENSe:UNIT?

SENSe:TCouple:TYPE {E|J|K|N|R|S|T}

SENSe:TCouple:SIMulated {<value>|MINimum|MAXimum}

3.1.8 Remote Interface Selection

The DL-1060 Series provide USB, GP-IB, and RS-232C interfaces: DL-1060 provides USB interface, and DL-1060G/VG provides both GP-IB and USB interfaces, and DL-1060R/VR provides both RS-232C and USB interfaces, but only one interface can be activated at a time. If you are using GPIB, you must set the address for the multimeter. You can set the address to any value from 0 and 31. The address is set to "22" when the multimeter is shipped from the factory.

※ Note: The remote interface can only be set through the front panel operations.

How to select a remote interface

1. Press SHIFT + CONFIG buttons. Then use ◀ and ▶ buttons to locate "INTERFACE". Press ENTER to select it as shown in **Figure 3-15**.
2. Use ◀ and ▶ buttons to toggle between "USB" and "GPIB(or RS232)". Press ENTER on your choice of interface.

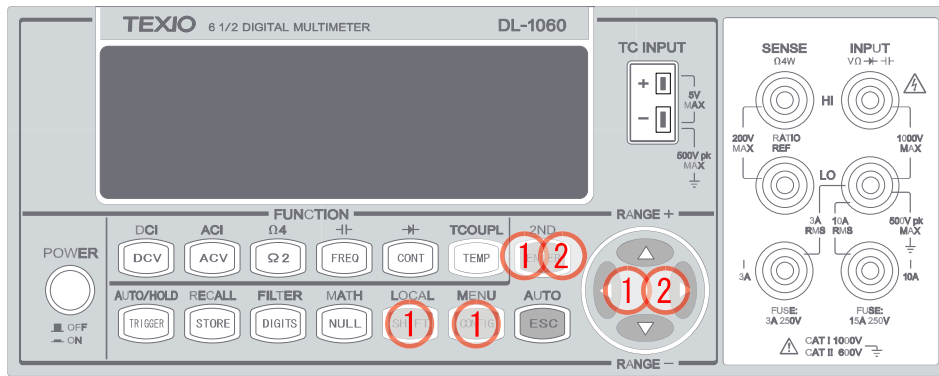

Figure 3-15

How to set the Address when using GP-IB

1. Press SHIFT + CONFIG buttons, and then use ◀ and ▶ buttons to locate "INTERFACE". Press ENTER to select it as shown in **Figure 3-16**.
2. Use ◀ and ▶ buttons to locate "GPIB". Press ENTER to select it.
3. Use ◀ and ▶ buttons to move through the digits and ▲ and ▼ buttons to adjust the numbers to a desired GPIB address. Press ENTER to set the address.

How to set up RS-232C

The RS-232C interface port of DL-1060R uses 9-pin D-sub connector. To connect DL-1060R/VR to a PC or terminal, you must use "InterLink cable". This cable is also called "null-modem cable". If you selected NONE Flow Control, your PC has 25-pin connector, or etc. Then prepare a proper cable for your configuration. The connecting diagram is shown below.

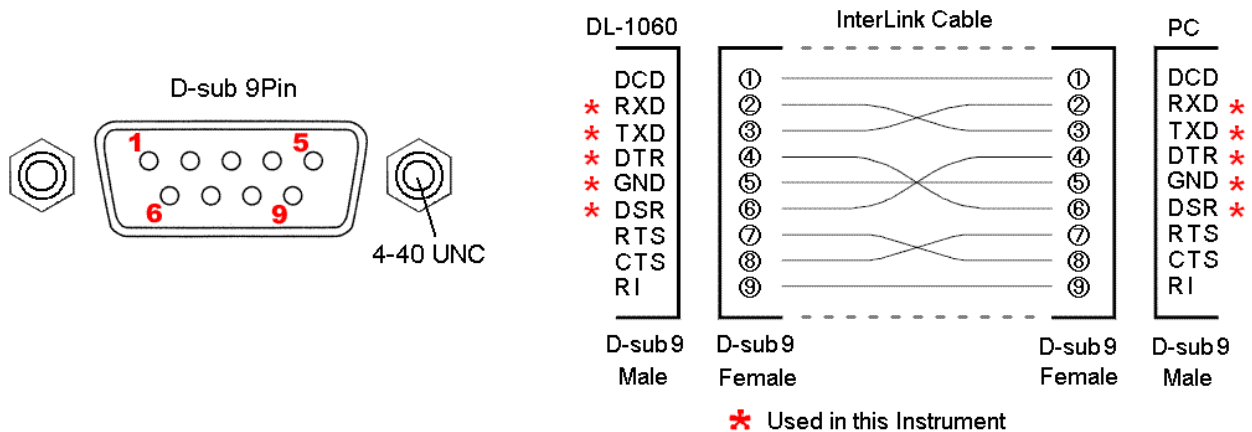

How to set the RS-232C configuration

1. Press SHIFT + CONFIG buttons, and then use ◀ and ▶ buttons to locate "INTERFACE". Press ENTER to select it as shown in **Figure 3-16**.
2. Use ◀ and ▶ buttons to locate "RS232". Press ENTER to select it. Then use ◀ and ▶ buttons to locate "BAUD RATE", "DATA BITS", "PARITY", "STOP BITS", or "FLOW CONTROL". Press ENTER to select it

3. Use ◀ and ▶ buttons to select the desired option. Press ENTER to set it.
- BAUD RATE: 300, 600, 1200, 2400, 4800, 9600, 19200, 38400, 57600, or 115200(bps)
- DATA BITS: 7 BITS or 8 BITS
- PARITY: NONE, ODD, or EVEN
- STOP BITS: 1 BIT or 2 BITS
- FLOW CONTROL: NONE or DTR/DSR
- Delimiter: LF(fixed)

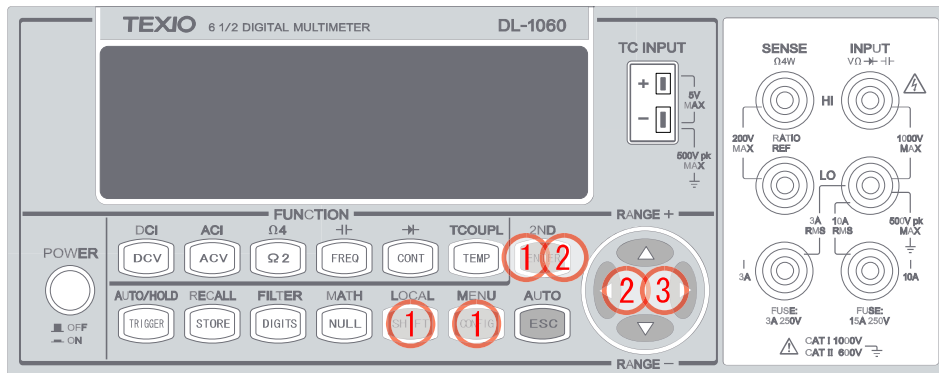

Figure 3-16

3.2 Trigger Operations

The triggering system of the DL-1060 will be explained in this section.

DL-1060 provides a various trigger operations such as trigger mode, trigger source, and different trigger settings for a specific measurement. The selected setup will be stored into the volatile memory and it returns to the default mode after power off.

Following **Figure 3-17** describes the detail of the trigger setup.

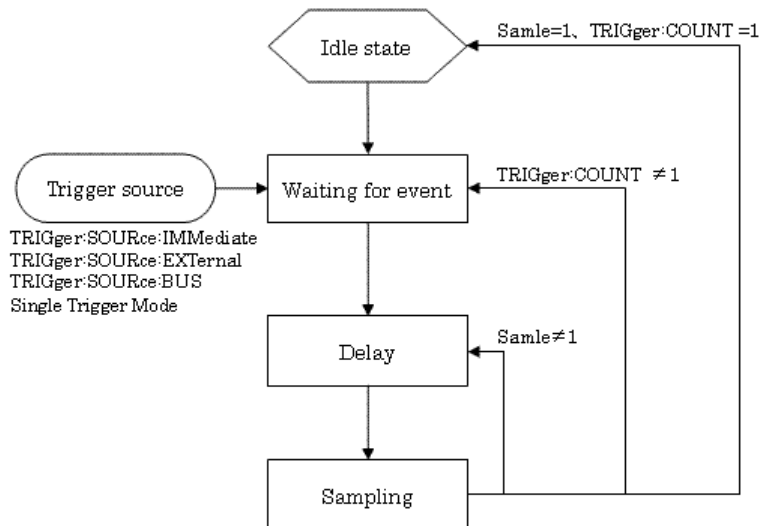

Trigger Operation Flow Chart

Figure 3-17

The trigger system is supposed to be in an idle status when DL-1060 is not measuring.

(*(sampling)display will illuminates when measurement is in progress)

When starting measurement after idle status, the trigger system should be in trigger waiting status. To make is in trigger waiting status, execute one of the following command via remote interface.

INTiate

READ?

MEASure?

While DL-1060 is in trigger waiting status(Waiting for event), the measurement operation will starts after execution of trigger delay, when the trigger condition matches by detecting trigger signal from the selected trigger source etc. The operation form the front panel will always be trigger waiting status then receives trigger signal at any time.

3.2.1 Trigger Mode

There are three trigger modes in DL-1060: auto, immediate, and single triggering. You can specify the trigger mode for your measurement. The factory default is auto triggering when the meter is power-on.

A. Auto Triggering Mode (Front Panel Operation only)

Definition

Auto triggering takes continuous readings at a fastest rate possible for the present measurement. The rate of taking readings depends on the current settings. This function is only available through the front panel. The auto triggering is also the default for trigger mode in DL-1060.

How to use Auto Trigger

1. Press SHIFT and TRIGGER on the front panel to enable auto trigger mode as shown in **Figure 3-18**.

※ Note: This operation is only used to return from Single Triggering Mode.

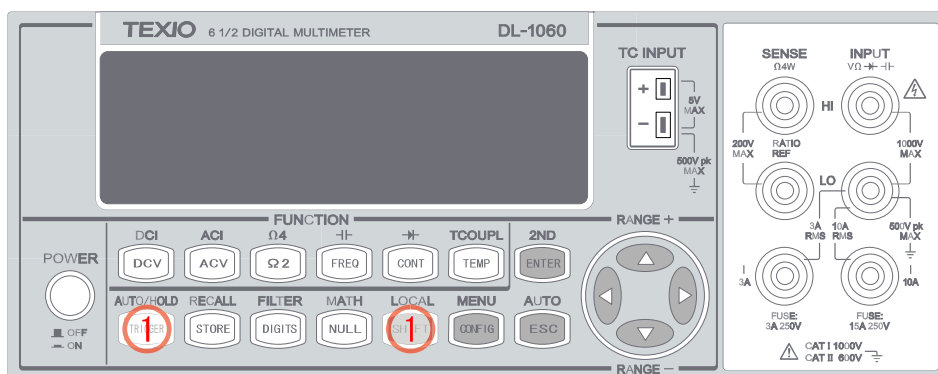

Figure 3-18

B. Internal Immediate Trigger Mode (Remote Interface Operation Only)

Definition

The immediate triggering mode is only available through the remote interface operations and it is the default for the remote interface operations. When the meter is in immediate trigger mode, a trigger will be issued immediately as soon as the meter is in "wait for event" state.

3.2.2 Trigger Source

In DL-1060, you can specify the trigger source to be one of these three options: front panel operations, external hardware trigger source and remote interface operations.

Front Panel Operation

Use SHIFT + TRIGGER buttons for auto triggering and TRIGGER button for single triggering.

External Hardware Trigger

You apply a trigger pulse to the EXT TRIG (BNC) terminal on the rear panel. External hardware triggering is like using single trigger but the trigger source is an external hardware. When the multimeter receives a pulse from the trigger source, it takes one reading, or a specified number of readings. To set the external hardware trigger, connect an external source to Ext TRIG terminal on the rear panel, and press TRIGGER buttons to enable external hardware trigger.

External Trigger Terminal

You can trigger the DL-1060 by using a low-true pulse to the Ext Trig (external trigger) terminal located on the rear panel. And to use this terminal via the remote interface, you have to select the external trigger source by using the **TRIGer:SOURce EXTERNAL** command.

Figure EXT TRIG (Input) pulse

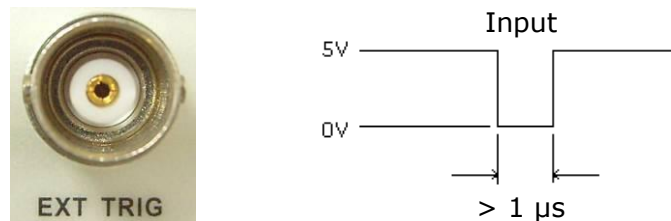

VM COMP (Voltmeter Complete) Terminal

The rear panel VM COMP terminal provides a low-true pulse after finishing each measurement. The VM COMP and external trigger shown below provides a standard hardware handshake sequence between measurement and switching devices.

Figure VM COMP (Output) pulse

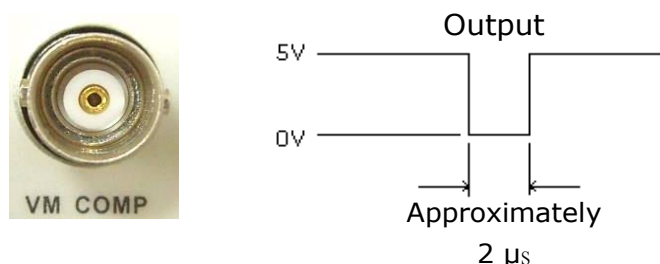

Remote Interface Operation (By software or internal trigger)

By software trigger: The software trigger is similar to the single triggering, but instead of using the "TRIGGER" button on the front panel, you send a command from your PC to the multimeter to generate an event. For using software trigger, use the following command from your PC terminal to set trigger source:

TRIGger:SOURce BUS

By internal trigger: The internal trigger is the default trigger mode for the Remote Interface Operation. In the internal trigger mode, a trigger signal will be issued whenever the multimeter is in the wait-for-trigger state. To set the internal trigger, use the following command from your PC terminal:

TRIGger:SOURce IMMEDIATE

3.2.3 Trigger Setting

In DL-1060, you can specify a variety of trigger settings including the number of samples per trigger, the number of triggers per event, reading hold, and the trigger delay for your measurements.

A. Number of samples on each trigger

By default, the multimeter takes only one reading on each trigger, but you can instruct the multimeter to take specific number (up to 2000) of readings each time it receives a trigger. The defined input setting is stored in a volatile memory which will be cleared after the meter has been turned off and the default value will be restored. You can set the number of samples on each trigger through front panel or the remote interface.

Front Panel Operation

1. Press SHIFT+CONFIG buttons as shown in **Figure 3-20**.
2. Set a defined parameter via the procedure TRIG SYS > TRIG CNT > ENTER.
3. Set the desired number by pressing Δ and ∇ buttons to increase or decrease the number, and using \triangleleft and \triangleright buttons to move through the digits. Press ENTER to set the number.

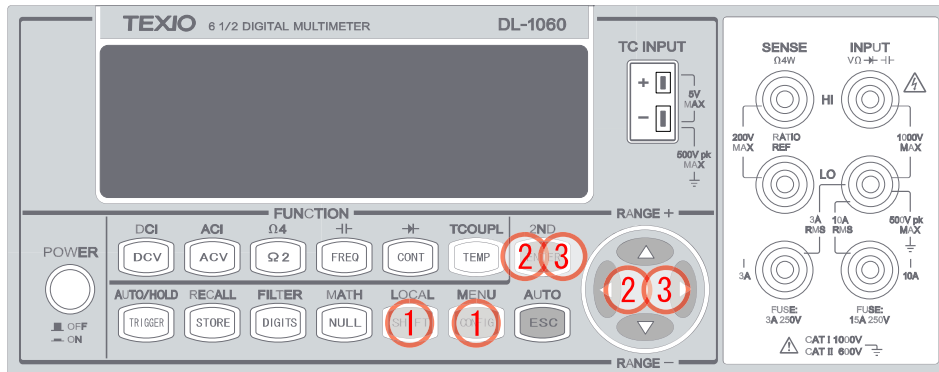

Figure 3-20

Remote Interface Operation

Use the following command to set the number of samples from your PC terminal.

SAMPLE:COUNT <value>

B. Number of triggers

Although the meter normally takes one trigger before returning to the "idle" state, you can manually specify the number of triggers it accepts before the "idle" state. However, this can only be done through the remote interface. The following command shows how to set multiple triggers before returning to idle state.

TRIGger:COUNT <value>

C. Reading hold (Front panel operation only)

The reading hold feature is used to hold a stable reading on the display. When a reading is stable, enabling the reading hold will hold the stable reading and trigger a beeping sound. Reading hold feature depends on an adjustable sensitivity band to determine if a reading is stable. The multimeter considers a reading stable when three consecutive readings are within Sensitivity Band (Hold) will explain how to adjust the sensitivity band. This feature is only available from the front panel operation.

How to enable/disable reading hold

1. Press SHIFT+TRIGGER buttons.
2. To disable it, press SHIFT+TRIGGER buttons again as shown in **Figure 3-21**.

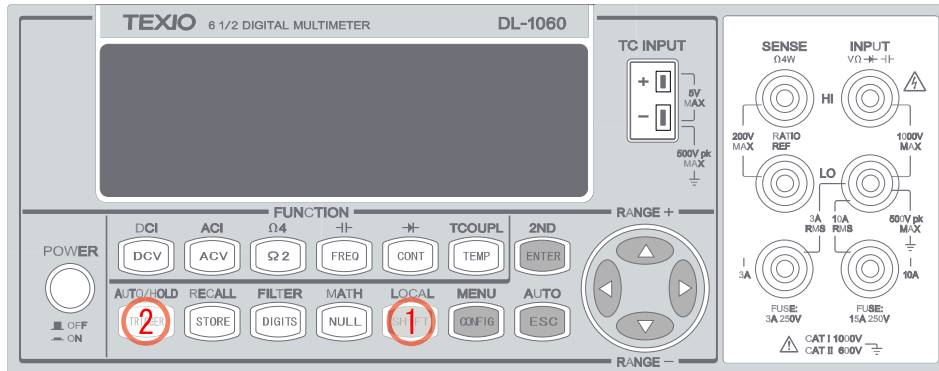

Figure 3-21

D. Trigger delay

This feature is useful for user who needs a longer delay time to wait for the system to be stabilized. The time needed to stabilize a measurement system is called the "settling time." The settling time depends on the measurement range, cable properties and signal source.

Defaults

The default of the trigger delay is automatic. DL-1060 automatically selects a delay time for you according to the setting of the measurement if you do not specify a delay. A list of the default for each measurement function is shown on **Table 3-4**. The range for the delay is from 0 to 3600 seconds. The defined selection of delay time is stored in a volatile memory and the default will be restored when the meter is power-off.

The internal settings of automatic trigger delay

The delay time for automatic trigger delay is determined by the selection of measurement function, range, and the setting of integration time and AC filter speed. The following table shows the default delay time for each measurement setting.

Table 3-4

Measurement Function	Setting	Trigger Delay Time
DCV/DCI	PLC \geq 1	<i>1.5 ms</i>
	PLC $<$ 1	<i>1.0 ms</i>
Ω 2 and Ω 4 (PLC \geq 1)	100 Ω to 100k Ω	<i>1.5 ms</i>
	1 M Ω	<i>15 ms</i>
	10 M Ω to 100 M Ω	<i>100 ms</i>
Ω 2 and Ω 4 (PLC $<$ 1)	100 Ω to 100k Ω	<i>1.0 ms</i>
	1 M Ω	<i>10 ms</i>
	10 M Ω to 100 M Ω	<i>100 ms</i>
ACV/ACI (Remote Interface/ External Trigger/ Single Trigger)	3 Hz	<i>7.0 s</i>
	20 Hz	<i>1.0 s</i>
	200 Hz	<i>600 ms</i>
ACV/ACI (Front Panel / Auto Trigger On)	3 Hz	<i>1.5 s</i>
	20 Hz	<i>200 ms</i>
	200 Hz	<i>100 ms</i>
Frequency/Period	Remote Interface / External	<i>1.0 s</i>
	Front Panel / Auto Trigger ON	<i>0 s</i>
Capacitance	1 nF to 10 mF	<i>0 s</i>

How to specify a delay time

User can set the delay time from either the front panel operations or the remote interface operations.

Front Panel Operation

1. Press SHIFT+CONFIG buttons as shown in **Figure 3-22**.
2. Set a defined parameter via the path TRIG SYS > DELAY > MANUAL > ENTER.
3. Use ◀ and ▶ buttons to move through the digits and ▲ and ▼ buttons to increase or decrease the numbers to set the desired delay time (between 0 to 3600 second). Then press ENTER to actuate the delay time.

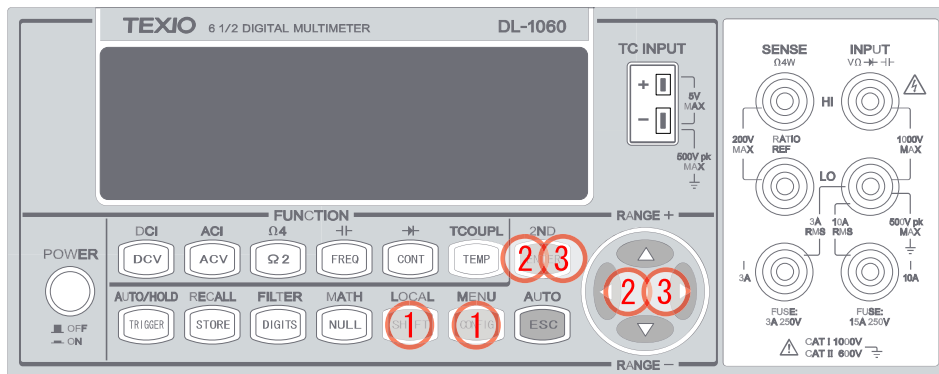

Figure 3-22

Remote Interface Operation

You can also use the remote interface operations from your PC terminal to set the trigger delay. To select a delay time, use the following command or set the trigger delay to be automatic:

TRIGger:DElay {<seconds>|MINimum|MAXimum}

or

TRIGger:DElay:AUTO {OFF|ON}

3.3 Math Operations

This section will introduce the mathematical operations in DL-1060. There are eight math operations: PERCENT, AVERAGE, NULL, LIMITS (HIGH LIMIT/LOW LIMIT), MX+B, dB and dBm testing. They either store data for later use or perform mathematical operations on the readings. Note that these math operations are available to all measurement functions except diode and continuity testing.

※ Note: The "MATH" annunciator on the display indicates the state of a mathematical feature, excluding Ratio, and will be lit when enabling whichever math feature

3.3.1 Percent(%)

Definition

This mathematical function calculates the ratio of a measurement reading to a specified target value as the form of percentage. The calculation formula is shown below:

$$\text{Percent} = \frac{\text{Input Reading}}{\text{Target Value}} \cdot 100$$

The specified target value is store in a volatile memory and will be cleared after the meter has been turned off or a remote interface reset.

How to use Percent function

There are two ways to make a percent measurement: Through the front panel operation or through the remote interface operation.

Front Panel Operation

1. Press SHIFT + NULL to enter MATH submenu as shown in **Figure 3-23**.
2. Set a difined parameter via the path PERCENT > TARGET > ENTER.
3. Use ◀ and ▶ and to move through the digits and ▲ and ▼ buttons to increase or decrease the numbers to a desired target value. Press ENTER to confirm and use the value. Observe the calculated percent value on the display.

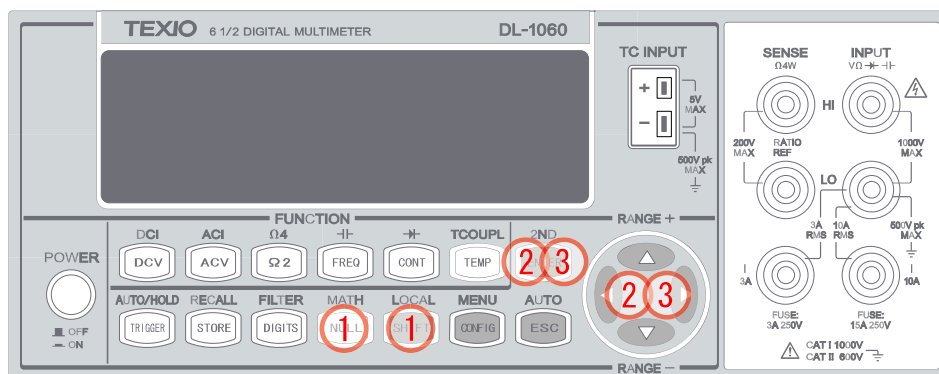

Figure 3-23

※Note: To disable the percent function, you need to go into MATH submenu by pressing SHIFT + NULL buttons and select "OFF" to turn it off. The "MATH" annunciator should not be lit when disabled.

Remote Interface Operation

Use the following commands to enable and configure Percent function:

CALCulate:FUNction PERCent

CALCulate:STATE {OFF|ON}

CALCulate:STATE?

CALCulate:PERCent:TARGet {<value>|MINimum|MAXimum}

CALCulate:PERCent:TARGet? [MINimum|MAXimum]

Remote Interface Operation

The following commands show you how to use the Average operation from your PC terminal.

CALCulate:FUNCTION AVERage

CALCulate:STATe {OFF|ON}

CALCulate:STATe?

CALCulate:AVERage:MINimum?

CALCulate:AVERage:MAXimum?

CALCulate:AVERage:AVERage?

CALCulate:AVERage:COUNT?

3.3.3 Null(Relative)

Definition

When the null function is enabled, the displayed measurement reading will show something difference between the measured input signal reading and the stored null (also called relative) value. The null (relative) value is stored in a volatile memory and the value will be cleared when the multimeter is power-off. Moreover, you can specify or alter a null value. The null function is available for all types of measurement except continuity and diode. When you select the null function for a measurement, it is visible only for this measurement.

How to operate null (relative) measurement

You can operate the null function from either the front panel operation or the remote interface operation.

The Front Panel Operation

Way One:

Store the null test lead resistance: First of all, short the two test leads together and then press NULL button. The new reading taken will replace the old value, if any, in the null register. Then, connect the two test leads to the input source. The value with null offset will show on the display.

Way Two:

Pressing NULL to actuate it. Or you want to define the value by doing the procedure SHIFT + NULL > NULL > ENTER > RUN VALUE as shown in **Figure 3-24**. And use ◀ and ▶ to move through the digits and ▲ and ▼ to increase or decrease the numbers to a desired value. Then press ENTER to actuat it.

※Note: Press NULL again to disable this feature. The "MATH" annunciator on the display indicates the state of a mathematical feature.

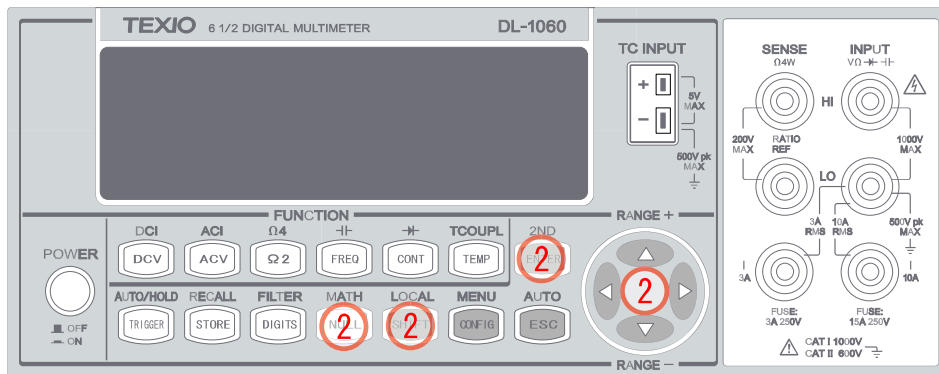

Figure 3-24

※Note: Press NULL button again or press other measurement buttons to disable this feature. The “MATH” annunciator on the display indicates the state of a mathematical operation.

The Remote Interface Operation

You can use the following commands on your PC terminal to make a null measurement.

CALCulate:FUNCTION NULL

CALCulate:STATE {OFF|ON}

CALCulate:STATE?

CALCulate:NULL:OFFSet {<value>|MAXimum|MINimum}

3.3.4 Limits Test

The limits testing operation allows user to adjust a maximal and a minimal limit values. The multimeter beeps and an “HI” or “LO” message will be shown when the reading exceeds the upper or lower limit respectively. You can specify the limit values and the values are stored in a volatile memory. The default values for both upper and lower limits are “0”. This function is available to all except continuity and diode measurements.

How to set the limits

You can set the limits or make a limit testing either through the front panel or the remote interface operation.

Front Panel Operation

1. Do the procedure SHIFT + NULL > LIMITS > ENTER > HIGH LIMIT/LOW LIMIT > ENTER to access the setting as shown in **Figure 3-25**
2. Use ◀ and ▶ to toggle between options. Press ENTER on your selection of LOW LIMIT or HIGH LIMIT.
3. Use ◀ and ▶ to move through the digits and ▲ and ▼ to increase or decrease the numbers to a desired value, then confirm the value with ENTER button. Press ENTER on "RUN" to start measurement.

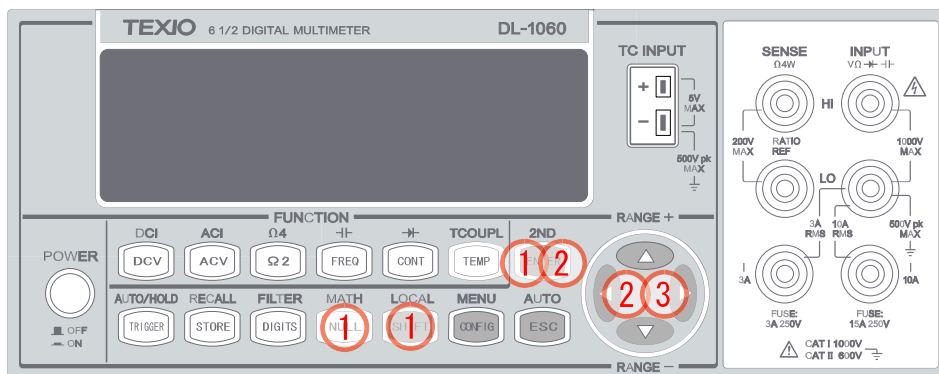

Figure 3-25

※Note: To disable the limits function, you always need to go to Math submenu and select "OFF" or press other measurement buttons. The "MATH" annunciator should not be lit when disabled

Remote Interface Operation

Use the following commands to enable the limits function or to set the limits:

CALCulate:FUNctioN LIMit

CALCulate:STATe {OFF|ON}

CALCulate:STATe?

CALCulate:LIMit:LOWer {<value>|MINimum|MAXimum}

CALCulate:LIMit:LOWer? [MINimum|MAXimum]

CALCulate:LIMit:UPPer {<value>|MINimum|MAXimum}

CALCulate:LIMit:UPPer? [MINimum|MAXimum]

Acquisition of limit test's result

The result for Pass/Fail test may be acquired from the USB connector located at rear panel for DL-1060.

Please refer "4.1 Pass/Fail Output From USB Connector" for detail.

3.3.5 MX+B

Definition

This mathematical function multiplies a measurement reading (X) by a specified scale factor (M) and add an offset (B) automatically. The answer (Y) will then be shown on the display according to the following equation.

$$Y=MX+B$$

This is especially useful when you need to do slope calculations on a series of measurements. The values of the "M" and "B" can be changed through the configuration of this function and they are stored in a volatile memory and will be cleared after the meter has been turned off or a remote interface reset.

How to use MX+B function

You can use MX+B function from the front panel operation or the remote interface operation.

Front Panel Operation (To set the values of M and B)

1. Do the procedure SHIFT + NULL > MX+B > ENTER > SET M/SET B > ENTER to access the setting as shown in **Figure 3-26**
2. Use ◀ and ▶ to move through the digits and use ▲ and ▼ to increase or decrease the number to a desired value under the SET M and SET B setting mode. Press ENTER to confirm the value and actuate the function.

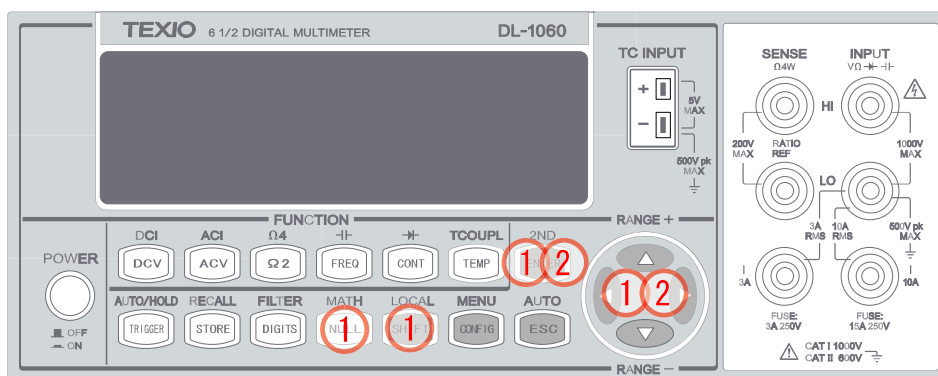

Figure 3-26

Remote Interface Operation

Use the following commands to enable and configure MX+B function:

CALCulate:FUNCTION MXB

CALCulate:STATE {OFF|ON}

CALCulate:STATE?

CALCulate:MXB:MMFactor {<value>|MINimum|MAXimum}

CALCulate:MXB:MMFactor? [MINimum|MAXimum]

CALCulate:MXB:MBFactor {<value>|MINimum|MAXimum}

CALCulate:MXB:MBFactor? [MINimum|MAXimum]

3.3.6 dB/dBm

A. dB Definition

The dB feature takes a DC or AC voltage measurement and displays it in decibel unit in correspondence to a relative reference value. The calculation of dB is listed below:

$$\text{dB} = (\text{Input signal in dBm}) - (\text{Relative value in dBm})$$

The dB measurement is applied to DC and AC voltage only. The relative value is adjustable and is stored in a volatile memory. The range for the relative value is between 0 dBm and 200 dBm, and the default value is 0 dBm.

How to use dB feature

You can either manually select a number for the relative reference or let the multimeter take the first reading (0 dB) as the relative reference.

Front Panel Operation (to set the relative reference)

1. Select a measurement function by pressing DCV or ACV button as shown in **Figure 3-27**.
2. Do the procedure SHIFT + NULL > dB > ENTER > dB REL to access the setting.
3. Use ◀ and ▶ to move through the digits and ▲ and ▼ buttons to increase or decrease the numbers to your desired value. Press ENTER to set the value.
4. Press ENTER on "RUN" to start measurement.

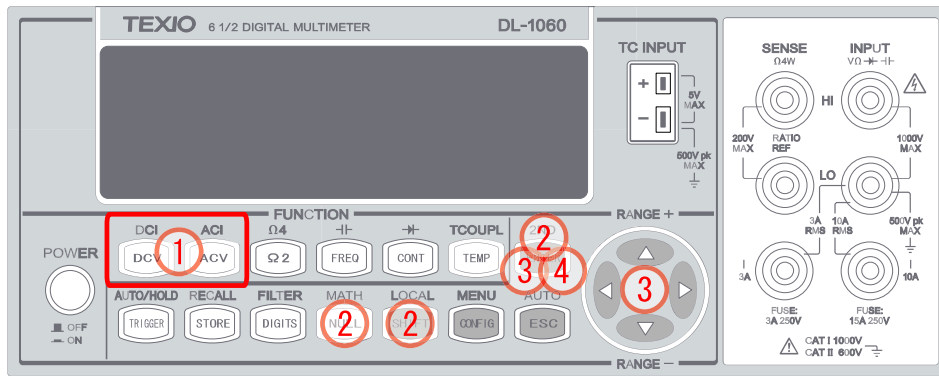

Figure 3-27

※ Note: To disable the dB function, you always need to go to Math submenu and select “OFF” or press other measurement buttons. The “MATH” annunciator should not be lit when disabled.

Remote Interface Operation

Use the following commands from your PC terminal to make the dB measurement:

CALCulate:FUNCTION DB

CALCulate:STATE {OFF|ON}

CALCulate:STATE?

CALCulate:DB:REfERENCE {<value>|MINimum|MAXimum}

B. dBm

Definition

With dBm selected, a voltage measurement is displayed as the level of power, relative to 1 milliwatt, dissipated through a reference resistance. The reference resistance is adjustable in DL-1060. The calculation of dBm is defined as below:

$$dB_m = 10 \times \log \left(\frac{V_{in}^2}{Z_{ref}} \right) / 1mW$$

- ※ Note 1: V_{in} is the input signal voltage. Z_{ref} is the reference resistance.
- ※ Note 2: Change of reference resistance will not affect the stored relative reference value.
- ※ Note 3: The Z_{ref} is adjustable with a range from 50Ω to 8000 Ω. The default value is 600 Ω.
- ※ Note 4: The defined selected reference value is stored in a volatile memory and will be cleared after the multimeter has been power-off.
- ※ Note 5: This feature is available for DCV and ACV only.

How to set the reference resistance

User can set the reference resistance either through the front panel operation or the remote interface operation.

Front Panel Operation

1. Select a measurement function by pressing DCV or ACV button.
2. Do the procedure SHIFT + NULL > dBm > ENTER > REL RES to access the setting as shown in **Figure 3-28**.
3. Use ◀ and ▶ to move through the digits and ▲ and ▼ buttons to increase or decrease the numbers to your desired value. Press ENTER to set the value.
4. Press ENTER on "RUN" to start measurement.

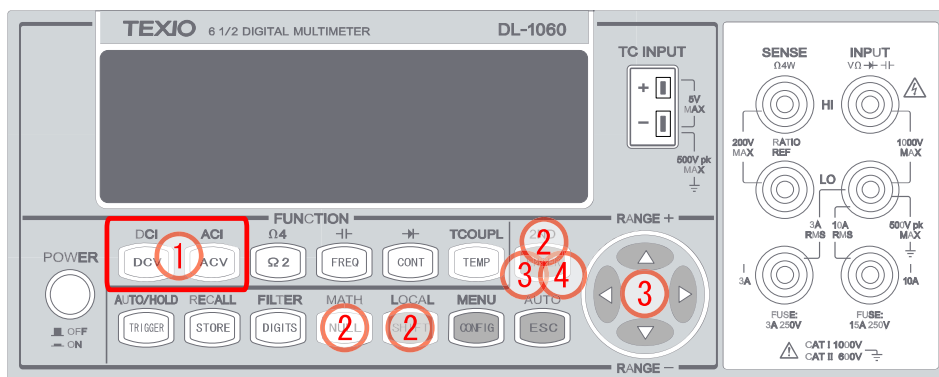

Figure 3-28

※ Note: To disable the dBm function, you always need to go to Math submenu and select "OFF" or press other measurement buttons. The "MATH" annunciator should not be lit when disabled.

Remote Interface Operation

Use the following commands to enable dBm feature or to set the reference resistance:

CALCulate:FUNctioN DBM

CALCulate:STATe {OFF|ON}

CALCulate:STATe?

CALCulate:DBM:REFerence {<value>|MINimum|MAXimum}

3.4 System Related Operations

In DL-1060, each system related operation performs a task that is not measurement related but plays an important role in making your measurements.

3.4.1 Display

DL-1060 has a dual-LCD-display screen. A maximum of 11 characters are allowed for upper row primary display and a maximum of 16 characters are allowed for lower row secondary display as shown on **Figure 3-29**. You have an option to turn off the display for a faster measurement without waiting for display, or when the measurement is done through the remote interface operations on their PC terminal.



Figure 3-29

When the display is turned off, an "OFF" will be lit at right side of the display screen. This doesn't mean the display is POWER-OFF, but only that the measurement readings will not be sent to the display. This option will accelerate the measurement process because there is no I/O delay. But turning off the display will not affect the messages displayed from the RECALL, MENU and CONFIG operations. You can send a message through the remote interface from their PC terminal to the lower row display and will substitute the original display.

Default

The display default is "ON". The "On/Off" selection made by you are stored in a volatile memory and the default (ON) will be restored when the meter is power-off.

How to control the display

You can control the display through the front panel operation or through the remote interface operation. The remote interface operation has higher priority over the front panel operation.

Front Panel Operation

Use the following steps to control the display:

1. Do the procedure SHIFT + CONFIG buttons > SYSTEM > ENTER > DISPLAY > ENTER > ON/OFF > ENTER to enable/disable the display as shown in **Figure 3-30**.

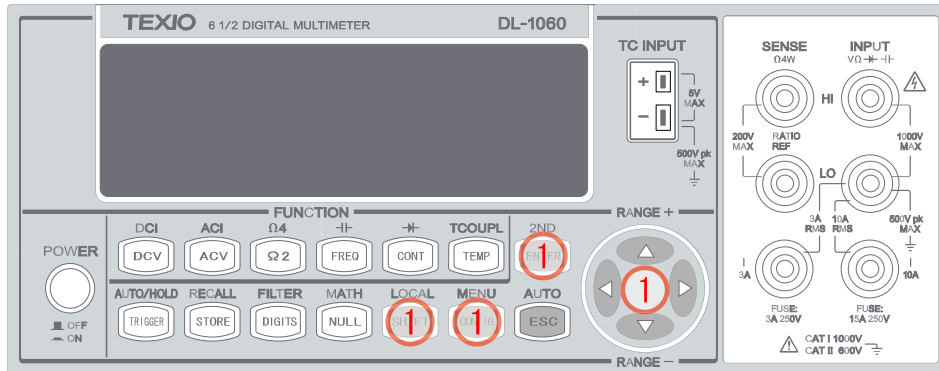

Figure 3-30

Remote Interface Operation

The following commands show how to control the display as well as how to send a message to the display:

DISPlay {OFF|ON} (turns off or turns on the display)

DISPlay:TEXT <quoted string> (displays the string you type in)

DISPlay:TEXT:CLEAr (clears the message displayed)

3.4.2 Beeper

DL-1060 beeps when some certain conditions are met or when an error occurs. But there may be time you want to disable the beeper for some operations. Although you can turn off the beeper, the click sound you hear when a button is pressed will not be disabled. The beeper state is stored in a volatile memory and the default will be restored when the meter has been turned off or after a remote interface reset.

By disabling the beeper you will not hear the meter beeps when:

- A new minimum or maximum is found in Min/Max operation.
- A stable reading is detected and held.
- The test voltage is within the limits in diode testing.
- The source signal fails the limit testing.

After the beeper is disabled, the meter still emits a tone when:

- An error occurs.
- Any button on the front panel is pressed.
- The threshold value is exceeded in continuity testing.

Default

The beeper is enabled when it is shipped from the factory.

How to control the beeper

User can control the beeper from either the front panel operation or the remote interface operation.

Front Panel Operation

1. Do the procedure SHIFT + CONFIG buttons > SYSTEM > BEEP > ON/OFF > ENTER to enable/disable the beep as shown in **Figure 3-31**.

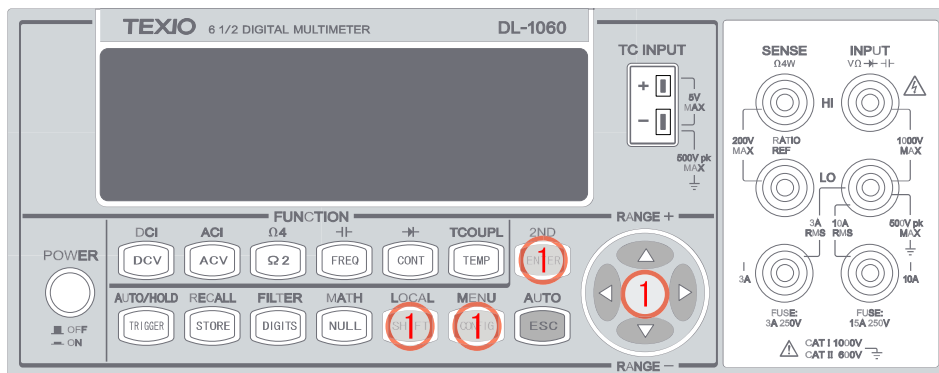

Figure 3-31

Remote Interface Operation

The following commands show how to use the remote interface operation to disable or enable the beeper:

SYSTEM:BEEPer

SYSTEM:BEEPer:STATe {OFF|ON}

3.4.3 Reading Memory (Store & Recall)

DL-1060 has a memory capacity of 2000 readings. The readings are stored in first-in-first-out order and the memory type is volatile, which means the stored readings will be cleared when the multimeter is power-off. The reading memory feature can be used for all measurement functions, math operations, trigger operations and reading hold. The default number of readings to store is 100 and the annunciator "MEM" will light up when STORE feature is enabled.

How to use the reading memory

You can store the readings and access to the stored readings through either the front panel operation or the remote interface operation.

※ Note: Each datum stored from DL-1060 to remote interface will be in a first in and first out condition.

Front Panel Operation

Before using the reading memory feature, you need to select a measurement function (or the math function) first and then select the trigger mode.

How to enable Reading Memory (to store readings)

Press STORE button, and the multimeter will start to store the readings produced until the specified number of readings is reached.

How to set the number of readings to be stored

1. Press SHIFT + CONFIG buttons as shown in **Figure 3-32**.
2. Do the procedure "TRIG SYS" > "STORE RDGS" > ENTER to set the number of readings. Use ◀ and ▶ buttons to move between the digits and ▼ and ▲ buttons to increase or decrease numbers as desired. When ready, press ENTER button.

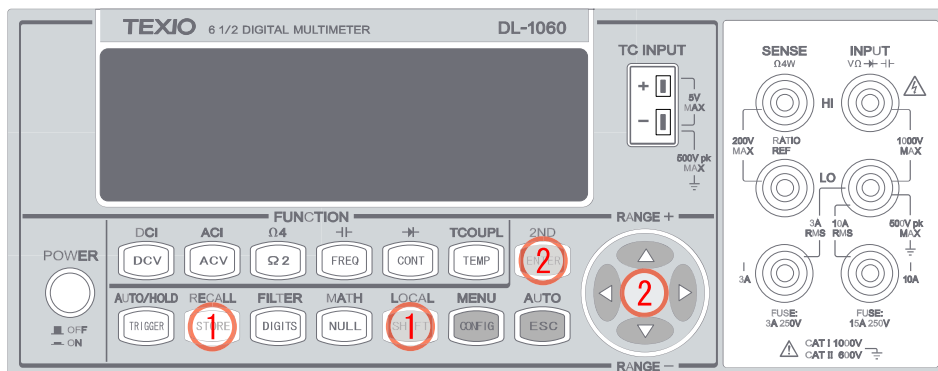

Figure 3-32

※ Note: The MEM annunciator will be lit while the multimeter stores readings and be turned off when the specified number of readings is reached.

How to recall the stored readings

1. Press SHIFT + STORE buttons, and the multimeter will display all the stored readings starting from the first reading. Use ◀ and ▶ buttons to move from the first reading to the last reading the meter has stored as shown in **Figure 3-33**.

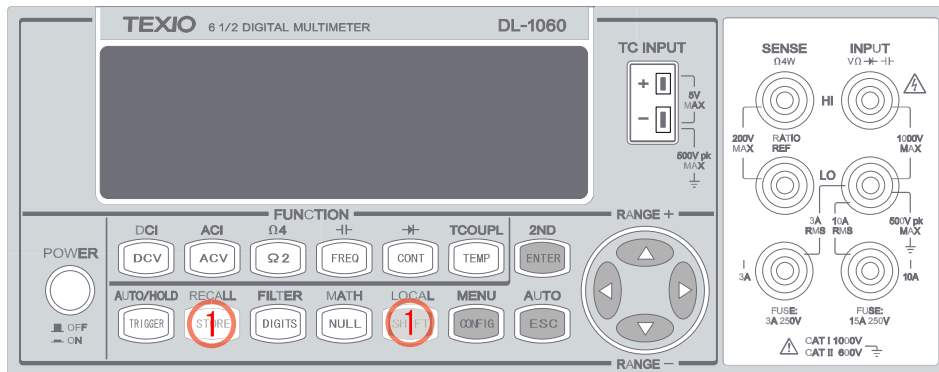

Figure 3-33

Remote Interface Operation

You can use the following commands from your PC terminal to store or retrieve readings in the memory. In addition, the number for STORE function only can be set through front panel.

INITiate (This command tells the meter to be on “wait-for-trigger” state. After a measurement is taken, measurement readings will be placed in the memory.)

FETCh? (Use this command to retrieve stored readings.)

DATA:POINTs? (Use this command to query the number of stored readings.)

3.4.4 Sensitivity Band (Hold)

The reading hold function captures and holds a stable reading on the display. DL-1060 beeps and holds the value when it detects a stable reading. The sensitivity band in reading hold decides which reading is stable enough. This band is expressed as a percent of reading on the selected range. DL-1060 considers a reading stable when three consecutive values are within the band. You have an option to adjust this sensitivity band.

Default

The default band is 0.1%. The defined selection is stored in a volatile memory and it will be cleared after the meter has been turned off.

How to enable/disable HOLD feature

1. Press SHIFT + TRIGGER buttons. The HOLD annunciator will light up when HOLD feature is enabled as shown in **Figure 3-34**.
2. To disable HOLD feature, press SHIFT + TRIGGER again.

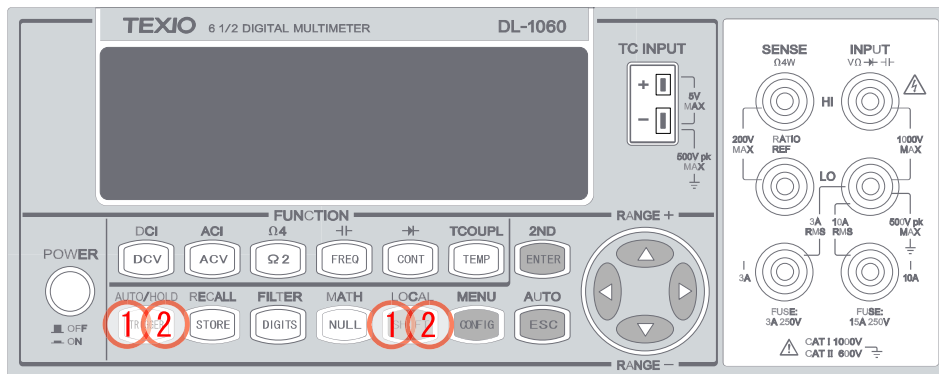

Figure 3-34

How to adjust the sensitivity band

You can adjust the sensitivity band through the front panel operation.

Front Panel Operation

1. Do the procedure SHIFT + CONFIG > TRIG SYS > READ HOLD > 0.01% / 0.1% / 1.0% / 10.0% to choose a desired band. Press ENTER on the desired sensitivity band.

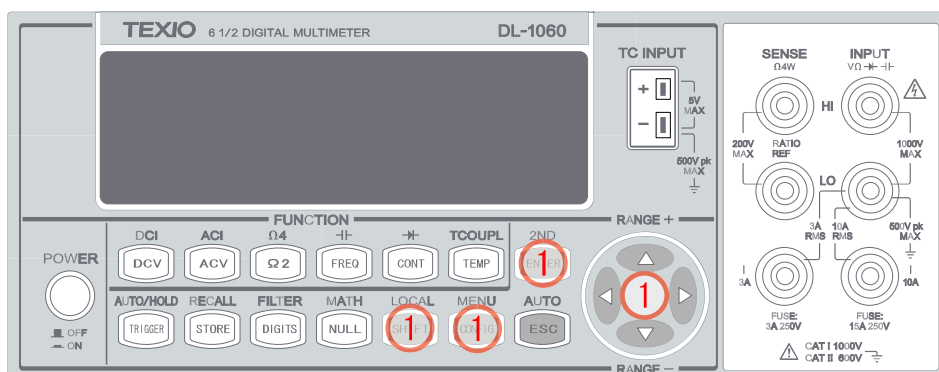

Figure 3-35

3.4.5 Initial Mode

The section contains two selections: "DEFAULT" and "SAVE DATA". You can select "SAVE DATE" to save the current configuration or select "DEFAULT SET" to restore the factory value after restarting DL-1060. The valid range of "SAVE DATA" is listed in **Table 3-5**.

Table 3-5

No.	Items of Save Data	Contents
1	Continuity	Threshold Resistance
2	Diode	Boundary Voltage
3	Temperature (RTD)	Sensor · Types · Units · USER define · SPRTD
4	Thermocouple	Types, Units, R Junction
5	dBm	Reference Resistance
6	MX+B	Values: M, B
7	Reading Hold	Sensitivity Band

How to save the settings

1. Do the procedure SHIFT + CONFIG > SYSTEM > ENTER > INIT MODE > ENTER > "SAVE DATA" / "DEFAULT SET" > ENTER to save your current setting or to resume the default setting as shown in **Figure 3-36**.

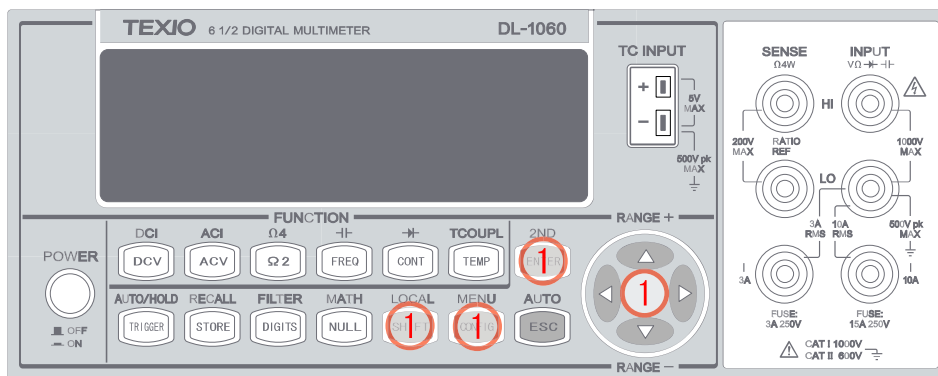

Figure 3-36

3.4.6 Language

DL-1060 supports two languages: DEFAULT (DL-1060) and COMPATIBLE(Keysight 34401A).

How to set up the language

1. Do the procedure SHIFT + CONFIG > SYSTEM > ENTER > LANGUAGE > ENTER > DEFAULT/COMPATIBLE > ENTER to select the language as shown in **Figure 3-37**.

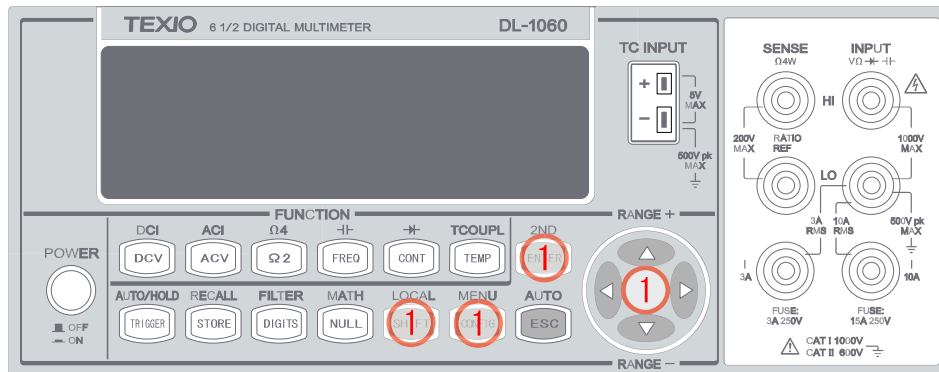

Figure 3-37

3.4.7 Error Condition

The error annunciator on the front panel display tells about the error condition of the multimeter. If there are one or more syntax or hardware errors found, the error annunciator will be lit to inform you. The multimeter stores errors using the first-in-first-out (FIFO) order and it records up to 20 errors in the error queue. The first error detected will be the first error retrieved. In addition, the general conditions of the ERROR are listed in the following. For more ERROR information, refer to Chapter 5 for the list of error messages.

※ Note:

- The error annunciator will be turned off when you have read the errors in the memory.
- If there is no error found when you check the error queue, the multimeter shows **"NO ERRORS"**.
- If there are more than 20 errors found, the last error in the error queue will be replaced with **"-350"**, means too many errors.
- The error queue is cleared when the multimeter is turned off, or when a *CLS command is received.

How to check the error queue

1. Do the procedure SHIFT + CONFIG > SYSTEM > ENTER > SCPI ERR > ENTER to

check the error message, such as “ERROR CODE” or “NO ERRORS” as shown in **Figure 3-38**.

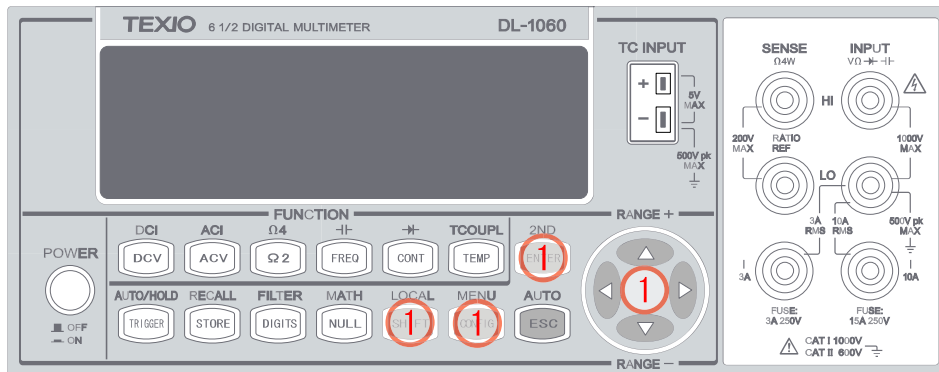

Figure 3-38

3.4.8 Firmware Revision

DL-1060 has three microprocessors for various internal systems. You can query the multimeter to determine which revision of firmware is installed for each microprocessor.

How to check the firmware revision

1. Do the procedure SHIFT + CONFIG > SYSTEM > SYSTEM VER > ENTER to check the DL-1060’s firmware version. The multimeter gives three numbers in xx-xx-xx format on the display. The first number is the firmware revision number for the measurement microprocessor; the second number is for I/O processor and the third number is for the front-panel processor as shown in **Figure 3-39**.

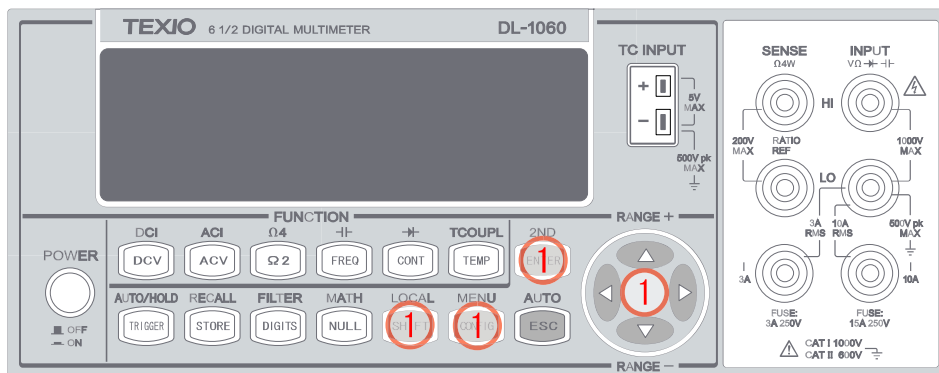

Figure 3-39

3.4.9 Calibration

※ **Notice:** Do not use “**CALIBRATE**” since it is aimed for maker calibration.

3.4.10 Self-test

※ **Notice:** Do not use **“SELF TEST”** since it is used only for an after sales service operation.

4 Remote Interface Operations

DL-1060 Series supports three remote interfaces: the built-in USB, GPIB (G type only), and RS232 (R type only). With GPIB, you will need a GPIB interface card. This chapter lists the SCPI (Standard Commands for Programmable Instrument) commands available to control the multimeter. For the first time to use SCPI, users would better to refer to Appendix B. for SCPI reference.

4.1 Pass/Fail Output From USB Connector

The USB connector on the rear panel of DL-1060 is a type-B connector. When the USB interface is **disabled**, the internal pass and fail TTL output signals (limit testing) will be transmitted to the USB connector.

The pass and fail signals are low true and indicate the Math Pass/Fail Limit Test result for the **next** reading to be output to the GPIB interface. The signals are active low for approximately 2ms ($\pm 100 \mu\text{sec}$) for each reading taken. **Figure 4-1** shows the USB connector (type-B).

Table 4-1

Contact Number	Signal Name	Typical Wiring Assignment	Description
1	VBUS	Red	Floating
2	D-	White	Limit Test Pass
3	D+	Green	Limit Test Fail
4	GND	Black	GND

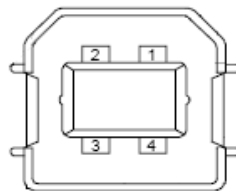

Figure 4-1

If you disable the USB interface, the Pass/Fail output function will enable automatically. Please follow the procedure below to enable/disable this function.

How to set Interface

1. Do the procedure SHIFT + CONFIG > INTERFACE > ENTER > USB > ENTER > ON/OFF > ENTER to set the interface.

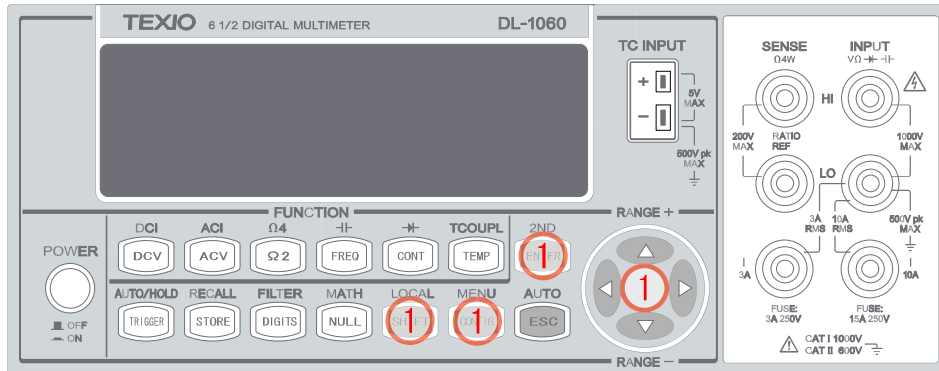

Figure 4-2



You can't use the USB interface if you want to enable the Pass/Fail signal output. You must use the GPIB interface (G type only) or remote control. Please disconnect the USB cable from your multimeter. The signal from the USB cable may make the Pass/Fail signal output abnormal.

4.2 Setting Up For Remote Interface

DL-1060 may be remote controlled through USB, GPIB interface (only G type), or RS-232 interface (only R type). Kind of interface should be selected in order to use remote interface. Please refer to chapter 3.1.8 for detail of selection. Next, following software should be installed into the PC for control.

-Following to NI-VISA3.1

-DL-1060 Driver

Also, application software for control is prepared into the attached CD besides of above software. Using this, an easy operation of multimeter from the PC is possible. Please refer install manual for detail of install method.

※ **Note:** Please download from our Web site (<http://www.texio.co.jp>) or from NI's Web site (<http://www.ni.com/visa>) for latest version of each software.

4.3 Remote Interface Commands

You can instruct the multimeter to take measurements by using the SCPI (Standard Commands for Programmable Instruments) commands after the appropriate setup for their selected remote interface.

The following conventions are used in SCPI command syntax.

- **Triangle brackets (<>)** indicates that you must specify a value for the enclosed parameter.
- **The square brackets ([])** indicates that the parameter is optional and can be omitted.
- **The braces { }** enclose the parameter choices for a given command string.
- **The vertical bar (|)** separates several choices for a parameter.

The MEASure? Command

Although it does not offer much flexibility, using the MEASure? Command is the simplest way to program the multimeter for measurements. You select the measurement function, range and resolution, the multimeter automatically sets the other parameters for you, make the measurement and send the result to the output buffer.

MEASure:

```
VOLTage:DC? {<range>|MIN|MAX|DEF},{<resolution>|MIN|MAX|DEF}
VOLTage:DC:RATio? {<range>|MIN|MAX|DEF },{<resolution>|MIN|MAX|DEF}
VOLTage:AC? {<range>|MIN|MAX|DEF},{<resolution>|MIN|MAX|DEF}
CURRent:DC? {<range>|MIN|MAX|DEF},{<resolution>|MIN|MAX|DEF}
CURRent:AC? {<range>|MIN|MAX|DEF},{<resolution>|MIN|MAX|DEF}
RESistance? {<range>|MIN|MAX|DEF},{<resolution>|MIN|MAX|DEF}
FRESistance? {<range>|MIN|MAX|DEF},{<resolution>|MIN|MAX|DEF}
FREQuency? {<range>|MIN|MAX|DEF},{<resolution>|MIN|MAX|DEF}
PERiod? {<range>|MIN|MAX|DEF},{<resolution>|MIN|MAX|DEF}
CONTinuity?
DIODE?
TCouple?
TEMPerature?
```

The CONFigure Command

The CONFigure command offers a little more flexibility than the MEASure? Command. The multimeter sets the parameters for the requested function, range and resolution, but does not make the measurements. You have an option to change the configuration. To initiate the measurement, use INITiate or READ? Command.

CONFigure:

```
VOLTage:DC {<range>|MIN|MAX|DEF},{<resolution>|MIN|MAX|DEF}
VOLTage:DC:RATio {<range>|MIN|MAX|DEF },{<resolution>|MIN|MAX|DEF}
```

VOLTage:AC {<range>|MIN|MAX|DEF},{<resolution>|MIN|MAX|DEF}
CURRent:DC {<range>|MIN|MAX|DEF},{<resolution>|MIN|MAX|DEF}
CURRent:AC {<range>|MIN|MAX|DEF},{<resolution>|MIN|MAX|DEF}
RESistance {<range>|MIN|MAX|DEF},{<resolution>|MIN|MAX|DEF}
FRESistance {<range>|MIN|MAX|DEF},{<resolution>|MIN|MAX|DEF}
FREQuency {<range>|MIN|MAX|DEF},{<resolution>|MIN|MAX|DEF}
PERiod {<range>|MIN|MAX|DEF},{<resolution>|MIN|MAX|DEF}
CONTinuity
DIODE
TCouple
TEMPerature

CONFigure?

The READ? Command

The READ? Command changes the state of the trigger system from the “idle” state to the “wait-for-trigger” state. When the specified trigger condition requirements are met after the multimeter receives the READ? command, the measurement will be initiated. The results are sent to the output buffer right away. You must enter the reading data into your bus controller or the multimeter will stop making measurements when the output buffer fills. Readings are not stored in the multimeter’s internal memory when using the READ? Command.

Using the READ? Command has a similar effect as using the INITiate command followed immediately by the FETCh? command, except readings are not buffered internally.

The INITiate and FETCh? Commands

These two commands provide the lowest level of control of measurement triggering and reading retrieval, but offer the most flexibility. After you have configured the multimeter, use INITiate command to change the state of the triggering system from the “idle” state to the “wait-for-trigger” state. The multimeter will start the measurements when the specified trigger condition requirements are met after it receives the INITiate command. The results are sent to the internal memory and stored until you are ready to read them.

The FETCh? command sends the data in the multimeter’s internal memory to the output buffer where you can read them into your bus controller.

The SENSE Commands

※ Note: Default parameters are shown in ***bold italic***.

[SENSe:]

FUNcTion "VOLTagE:DC"
FUNcTion "VOLTagE:DC:RATio"
FUNcTion "VOLTagE:AC"
FUNcTion "CURRent:DC"
FUNcTion "CURRent:AC"
FUNcTion "RESistance" (2-wire Ω)
FUNcTion "FRESistance" (4-wire Ω)
FUNcTion "FREQuency"
FUNcTion "PERiod"
FUNcTion "CONTInuity"
FUNcTion "DIODE"
FUNcTion "TCouple"
FUNcTion "TEMPerature"
FUNcTion "CAPacitrance"
FUNcTion?

[SENSe:]

VOLTagE:DC:RANGe {<range>|MINimum|MAXimum}
VOLTagE:DC:RANGe? [MINimum|MAXimum]
VOLTagE:AC:RANGe {<range>|MINimum|MAXimum}
VOLTagE:AC:RANGe? [MINimum|MAXimum]
CURRent:DC:RANGe {<range>|MINimum|MAXimum}
CURRent:DC:RANGe? [MINimum|MAXimum]
CURRent:AC:RANGe {<range>|MINimum|MAXimum}
CURRent:AC:RANGe? [MINimum|MAXimum]
RESistance:RANGe {<range>|MINimum|MAXimum}
RESistance:RANGe? [MINimum|MAXimum]
FRESistance:RANGe {<range>|MINimum|MAXimum}
FRESistance:RANGe? [MINimum|MAXimum]
FREQuency:VOLTagE:RANGe {<range>|MINimum|MAXimum}
FREQuency:VOLTagE:RANGe? [MINimum|MAXimum]
PERiod:VOLTagE:RANGe {<range>|MINimum|MAXimum}
PERiod:VOLTagE:RANGe? [MINimum|MAXimum]

[SENSe:]

VOLTage:DC:RANGe:AUTO {OFF|**ON**}
 VOLTage:DC:RANGe:AUTO?
 VOLTage:AC:RANGe:AUTO {OFF|**ON**}
 VOLTage:AC:RANGe:AUTO?
 CURRent:DC:RANGe:AUTO {OFF|**ON**}
 CURRent:DC:RANGe:AUTO?
 CURRent:AC:RANGe:AUTO {OFF|**ON**}
 CURRent:AC:RANGe:AUTO?
 RESistance:RANGe:AUTO {OFF|**ON**}
 RESistance:RANGe:AUTO?
 FRESistance:RANGe:AUTO {OFF|**ON**}
 FRESistance:RANGe:AUTO?
 FREQuency:VOLTage:RANGe:AUTO {OFF|**ON**}
 FREQuency:VOLTage:RANGe:AUTO?
 PERiod:VOLTage:RANGe:AUTO {OFF|**ON**}
 PERiod:VOLTage:RANGe:AUTO?

[SENSe:]

VOLTage:DC:RESolution {<resolution>|MINimum|MAXimum}
 VOLTage:DC:RESolution? [MINimum|MAXimum]
 VOLTage:AC:RESolution {<resolution>|MINimum|MAXimum}
 VOLTage:AC:RESolution? [MINimum|MAXimum]
 CURRent:DC:RESolution {<resolution>|MINimum|MAXimum}
 CURRent:DC:RESolution? [MINimum|MAXimum]
 CURRent:AC:RESolution {<resolution>|MINimum|MAXimum}
 CURRent:AC:RESolution? [MINimum|MAXimum]
 RESistance:RESolution {<resolution>|MINimum|MAXimum}
 RESistance:RESolution? [MINimum|MAXimum]
 FRESistance:RESolution {<resolution>|MINimum|MAXimum}
 FRESistance:RESolution? [MINimum|MAXimum]

[SENSe:]

UNIT {**CeI**|Far|K}
 UNIT?
 TCOuple:TYPE {E|J|**K**|N|R|S|T}
 TCOuple:TYPE?
 TCOuple:SIMulated {<value>|MINimum|MAXimum}
 TCOuple:SIMulated?

[SENSe:]

TEMPerature:RTD:TYPE {**PT100**|D100|F100|PT385|PT3916|USER|SPRTD|NTCT}
 TEMPerature:RTD:TYPE?
 TEMPerature:RTD:RZERo {<value>|MINimum|MAXimum}

TEMPerature:RTD:RZERo? [MINimum|MAXimum]
 TEMPerature:RTD:ALPHa {<value>|MINimum|MAXimum}
 TEMPerature:RTD:ALPHa? [MINimum|MAXimum]
 TEMPerature:RTD:BETA {<value>|MINimum|MAXimum}
 TEMPerature:RTD:BETA? [MINimum|MAXimum]
 TEMPerature:RTD:DELTA {<value>|MINimum|MAXimum}
 TEMPerature:RTD:DELTA? [MINimum|MAXimum]
 TEMPerature:SPRTD:RZERo {<value>|MINimum|MAXimum}
 TEMPerature:SPRTD:RZERo? [MINimum|MAXimum]
 TEMPerature:SPRTD:A4 {<value>|MINimum|MAXimum}
 TEMPerature:SPRTD:A4? [MINimum|MAXimum]
 TEMPerature:SPRTD:B4 {<value>|MINimum|MAXimum}
 TEMPerature:SPRTD:B4? [MINimum|MAXimum]
 TEMPerature:SPRTD:AX {<value>|MINimum|MAXimum}
 TEMPerature:SPRTD:AX? [MINimum|MAXimum]
 TEMPerature:SPRTD:BX {<value>|MINimum|MAXimum}
 TEMPerature:SPRTD:BX? [MINimum|MAXimum]
 TEMPerature:SPRTD:CX {<value>|MINimum|MAXimum}
 TEMPerature:SPRTD:CX? [MINimum|MAXimum]
 TEMPerature:SPRTD:DX {<value>|MINimum|MAXimum}
 TEMPerature:SPRTD:DX? [MINimum|MAXimum]

[SENSe:]

VOLTage:DC:NPLCycles
 {0.001|0.006|0.02|0.06|0.2|0.6|1|2|**10**|100|MINimum|MAXimum}
 VOLTage:DC:NPLCycles? [MINimum|MAXimum]
 CURRent:DC:NPLCycles
 {0.001|0.006|0.02|0.06|0.2|0.6|1|2|**10**|100|MINimum|MAXimum}
 CURRent:DC:NPLCycles? [MINimum|MAXimum]
 RESistance:NPLCycles {0.001|0.006|0.02|0.06|0.2|0.6|1|2|**10**|100|MINimum|MAXimum}
 RESistance:NPLCycles? [MINimum|MAXimum]
 FRESistance:NPLCycles
 {0.001|0.006|0.02|0.06|0.2|0.6|1|2|**10**|100|MINimum|MAXimum}
 FRESistance:NPLCycles? [MINimum|MAXimum]

[SENSe:]

FREQuency:APERture {0.01|**0.1**|1|MINimum|MAXimum}
 FREQuency:APERture? [MINimum|MAXimum]
 PERiod:APERture {0.01|**0.1**|1|MINimum|MAXimum}
 PERiod:APERture? [MINimum|MAXimum]

[SENSe:]

DETEctor: BANDwidth {3|**20**|200|MINimum|MAXimum}
 DETECTOR: BANDwidth? [MINimum|MAXimum]

[SENSe:]

AVERage: TCONtrol {**MOVing**|REPeat}
 AVERage: TCONtrol?
 AVERage: COUNT {<value>|MINimum|MAXimum}
 AVERage: COUNT? [MINimum|MAXimum]
 AVERage: STATE {OFF|**ON**}
 AVERage: STATE?

[SENSe:]

ZERO: AUTO {OFF|ONCE|**ON**}
 ZERO: AUTO?

INPut:

IMPedance: AUTO {**OFF**|ON}
 IMPedance: AUTO?

MATH OPERATION Commands

There are seven math operations. Only one of them can be enabled at a time. They either store data for later use or perform mathematical operations on the readings. Note that these seven math operations are available to all measurement functions except continuity and diode testing. The math operations use one or more internal registers. You can preset the values in some of the registers, while others hold the results of the math operations.

CALCulate:

FUNction {**PERCent**|AVERage|NULL|LIMit|MXB|DB|DBM}
 FUNction?
 STATE {**OFF**|ON}
 STATE?

CALCulate:

PERCent: TARGet {<value>|MINimum|MAXimum}
 PERCent: TARGet? [MINimum|MAXimum]

CALCulate:

AVERage: MINimum?
 AVERage: MAXimum?
 AVERage: AVERage?
 AVERage: COUNT?

CALCulate:

NULL:OFFSet {<value>|MINimum|MAXimum}
NULL:OFFSet? [MINimum|MAXimum]

CALCulate:

LIMit:LOWer {<value>|MINimum|MAXimum}
LIMit:LOWer? [MINimum|MAXimum]
LIMit:UPPer {<value>|MINimum|MAXimum}
LIMit:UPPer? [MINimum|MAXimum]

CALCulate:

MXB:MMFactor {<value>|MINimum|MAXimum}
MXB:MMFactor? [MINimum|MAXimum]
MXB:MBFactor {<value>|MINimum|MAXimum}
MXB:MBFactor? [MINimum|MAXimum]

CALCulate:

DB:REFeRence {<value>|MINimum|MAXimum}
DB:REFeRence? [MINimum|MAXimum]

CALCulate:

DBM:REFeRence {<value>|MINimum|MAXimum}
DBM:REFeRence? [MINimum|MAXimum]

DATA:FEED RDG_STORE,{“CALCulate”|””}
DATA:FEED?

TRIGGERING

DL-1060 provides a variety of trigger operations. You can select a trigger mode, a trigger source and different trigger settings for a specific measurement. Refer to **Figure 3-17** for triggering system flow chart. Triggering from a remote interface is a multi-step sequence. You must first configure the multimeter by choosing the desired function, range and resolution. Specify the trigger source from which the multimeter will accept the trigger. The multimeter takes immediate internal trigger, a software trigger from a remote interface and external trigger from the rear panel. Then be sure that the multimeter is ready for a trigger (in the "wait-for-trigger" state).

DL-1060 accepts a trigger only when it is in the "wait-for-trigger" state. When you have finished configuring the multimeter and have selected a trigger source, you need to place the multimeter in the "wait-for-trigger" state so it will take the trigger and make the measurement. The INITiate, READ? and MEASure? commands all place the multimeter to the "wait-for-trigger" state.

Triggering Commands

INITiate

READ?

TRIGger:

SOURce {BUS|**IMMediate**|EXTernal}

SOURce?

TRIGger:

DELay {<seconds>|MINimum|MAXimum}

DELay? [MINimum|MAXimum]

TRIGger:

DELay:AUTO {OFF|ON}

DELay:AUTO?

SAMPLE:

COUNT {<value>| MINimum|MAXimum }

COUNT? [MINimum|MAXimum]

TRIGger:

COUNT {<value>| MINimum|MAXimum|INFinite }

COUNT? [MINimum|MAXimum]

SYSTEM-RELATED Commands

Each system related operation performs a task that is not measurement related but plays an important role in making your measurements.

FEtCh?

READ?

DISPlay {OFF|**ON**}

DISPlay?

DISPlay:

TEXT <quoted string>

TEXT?

TEXT:CLear

SYSTem:

BEEPer

BEEPer:STATe {OFF|**ON**}

BEEPer:STATe?

SYSTem:ERRor?

SYSTem:VERSion?

DATA:POINts?

SYSTEM:IDNSTR "MANUFACTURER,PRODUCT"

*RST

*IDN?

L0

L1

STATUS REPORTING Commands

SYSTem:ERRor?

STATus:

QUEStionable:ENABle <enable value>

QUEStionable:ENABle?

QUEStionable:EVENt?

STATus:PRESet

*CLS

*ESE <enable value>

*ESE?

*ESR?
*OPC
*OPC?
*PSC {0|1}
*PSC?
*SRE <enable value>
*SRE?
*STB?

Other Interface Commands

SYSTem:LOCal
SYSTem:REMOte

GP-IB (IEEE-488.2) COMMON Commands

*CLS
*ESE <enable value>
*ESE?
*ESR?
*IDN?
*OPC
*OPC?
*PSC {0|1}
*PSC?
*RST
*SRE <enable value>
*SRE?
*STB?
*TRG

5 Error Message

Errors are retrieved in first-in-first-out (FIFO) order. The first error returned is the first error that was stored. When user has read all errors from the queue, the **ERROR** annunciator turns off. DL-1060 beeps once each time an error occurs.

Should more than 20 errors have existed, the last error stored in the queue (the most recent error) is replaced with -350, "Too many errors". No additional errors are saved until you remove errors from the queue, the multimeter responds with +0, "No error".

The error queue is cleared when power has been off or after a *CLS (clear status) command has been executed. The *RST (reset) command does not clear the error queue.

5.1 Error Type

There is only one type over here, "execution errors".

5.1.1 Execution Errors

- **-101 Invalid character**

An invalid character was found in the command string.

- **-102 Syntax error**

Invalid syntax was found in the command string.

- **-103 Invalid separator**

An invalid separator was found in the command string.

- **-104 Data type error**

A parameter type error was found in the command string.

- **-105 GET not allowed**

A Group Execute Trigger (GET) is not allowed in the command string.

- **-108 Parameter not allowed**

More parameters were found than needed for the command.

- **-109 Missing parameter**

Not enough parameters were received for the command.

- **-112 Program mnemonic too long**

A command header with too many characters was received.

- **-113 Undefined header**

An invalid command was received.

- **-121 Invalid character in number**

An invalid character was found in the number specified for a parameter value.

- **-123 Numeric overflow**

A numeric parameter with exponent larger than 32000 was found.

- **-124 Too many digits**

A numeric parameter was found whose mantissa contained more than 255 digits, excluding leading zeros.

- **-131 Invalid suffix**

A suffix was incorrectly specified for a numeric parameter.

- **-138 Suffix not allowed**

A suffix was received following a numeric parameter which does not accept a suffix.

- **-148 Character not allowed**

A discrete parameter was received but a character string or a numeric parameter was expected.

- **-151 Invalid string data**

An invalid character string was received.

- **-158 String data not allowed**

A character string was received but not allowed for the command.

- **-160~-168 Block data errors**

Block data is not acceptable.

- **-170~-178 Expression errors**

The meter does not accept mathematical expression.

- **-211 Trigger ignored**

A Group Execute Trigger (GET) or *TRG was received but the trigger was ignored.

- **-213 Trigger deadlock**

A trigger deadlock occurs when the trigger source is BUS and a READ? Command is received

- **-214 Init Ignored**

An INITiate command was received but could not be executed because a measurement was already in progress. Send a device clear to halt a measurement in progress and place the meter in the "idle" state.

- **-221 Settings conflict**

This error can be generated in one of the following situations:

Situation 1: You sent a CONFIGure or MEASure command with autorange enabled and with a fixed resolution.

Situation 2: You turned math on and then changed to a math operation that was not valid with the present measurement function.

- **-222 Data out of range**

A numeric parameter value is out of range.

- **-223 Too much data**

A character string was too long.

- **-224 Illegal parameter value**

A discrete parameter was received which was not a valid choice for the command.

- **-230 Data Stale**

A FETCh? Command was received but the memory was empty.

- **-350 Too many errors**

The error queue is full.

- **-243 Second function invalid**

It means Secondary function is not enabled.

- **-410 Query INTERRUPTED**

A command was received which sends data to the output buffer, but the output buffer contained data from a previous command.

- **-420 Query UNTERMINATED**

The multimeter was addressed to talk (i.e., to send data over the interface) but a command has not been received which send data to the output buffer.

- **-430 Query DEADLOCKED**

A command was received which generates too much data to fit in the output buffer and input buffer is also full. Command execution continues but all data is lost.

- **-440 Query UNTERMINATED after indefinite response**

The *IDN? Command must be the last query command within a command string.

- **223 2nd function mismatch**

It means function/2nd func mismatch.

- **521 Input buffer overflow**

- **522 Output buffer overflow**

- **531 Insufficient memory**

There is not enough memory to store the requested number of readings in internal memory using the INITiate command. The product of the sample count (SAMPLE:COUNT) and the trigger count (TRIGger:COUNT) must not exceed 2000 readings.

- **532 Cannot achieve requested resolution**

The multimeter cannot achieve the requested measurement resolution. You may have specified an invalid resolution in the CONFigure or MEASure command.

- **540 Cannot use overload as math reference**

The multimeter cannot store an overload reading (9.90000000E+37) as the math reference for null or dB measurements. The math state is turned off as a result of this condition.

- **550 Command not allowed in local**

The multimeter received a READ? Command while in the local mode.

- **225 Function/range mismatch**

It means function/range mismatch.

Appendix

A. Specification List

DC Characteristics Accuracy \pm (% of reading + % of range) [1]

<i>Function</i>	<i>Range</i> [2]	<i>Resolution</i>	<i>Input resistance</i>	<i>1 Year (23 °C \pm 5 °C)</i>
DCV (DC Voltage)	100.0000 mV	0.1 μ V	10 M Ω	0.008 + 0.0045
	1.000000 V	1 μ V	10 M Ω	0.009 + 0.001
	10.00000 V	10 μ V	10 M Ω	0.012 + 0.002
	100.0000 V	100 μ V	10 M Ω	0.012 + 0.002
	1000.000 V	1 mV	10 M Ω	0.02 + 0.003

<i>Function</i>	<i>Range</i> [2]	<i>Resolution</i>	<i>Shunt Resistance</i>	<i>1 Year (23 °C \pm 5 °C)</i>
DC Current	10.00000 mA	10 nA	5.1 Ω	0.05 + 0.02
	100.0000 mA	100 nA	5.1 Ω	0.05 + 0.01
	1.000000 A	1 μ A	0.1 Ω	0.15 + 0.02
	3.00000 A	10 μ A	0.1 Ω	0.2 + 0.03
	10.00000 A	10 μ A	0.005 Ω	0.25 + 0.05

<i>Function</i>	<i>Range</i>	<i>Resolution</i>	<i>Test Current</i>	<i>1 Year (23 °C \pm 5 °C)</i>
Resistance [3]	100.0000 Ω	100 $\mu\Omega$	1 mA	0.02 + 0.005
	1.000000 k Ω	1 m Ω	1 mA	0.02 + 0.002
	10.00000 k Ω	10 m Ω	100 μ A	0.02 + 0.002
	100.0000 k Ω	100 m Ω	10 μ A	0.02 + 0.002
	1.000000 M Ω	1 Ω	1 μ A	0.02 + 0.004
	10.00000 M Ω	10 Ω	0.1 μ A	0.1 + 0.004
	100.0000 M Ω	100 Ω	0.1 μ A (//10 M Ω)	1.5 + 0.005
Diode Test	1.0000 V	10 μ V	1 mA	0.02 + 0.02
Continuity	1000.00 Ω	10 m Ω	1 mA	0.02 + 0.03

[1] Specifications are for 2-hour warm-up condition, 10PLC and they're relative to calibration standards.

[2] 20% over range on all ranges except 1000Vdc and 3A/10A range.

[3] Specifications are for 4-wire or 2-wire when a Null operation is used.

Frequency and Period Characteristics Accuracy \pm (% of reading) [1]

Function	Range [2]	Frequency (Hz)	1 Year (23 °C \pm 5 °C)
Frequency & Period	100 mV to 750 V[4]	10 to 40	0.03
		40 to 300 k	0.02

[1] Specifications are for 2-hour warm-up condition, 6 1/2 digits and they're relative to calibration standards.

[2] 20% over range on all ranges except 750Vac range.

[4] The Range 750Vac is limited to 100kHz.

AC Characteristics Accuracy \pm (% of reading + % of range) [1]

Function	Range [2]	Resolution	Frequency(Hz)	1 Year (23 °C \pm 5 °C)
ACV (True RMS Voltage) [5]	100.0000 mV	0.1 μ V	10 to 20 k	0.12 + 0.05
			20 k to 50 k	0.25 + 0.05
			50 k to 100 k	0.65 + 0.08
			100 k to 300 k	4.8 + 0.8
	1.000000 V to 750.000 V[4]	1 μ V~1 mV	10 to 20 k	0.12 + 0.04
			20 k to 50 k	0.25 + 0.05
			50 k to 100 k	0.65 + 0.08
			100 k to 300 k	4.8 + 0.8
ACI (True RMS Current) [5]	1.000000 A	1 μ V	10 to 1 k	0.2 + 0.04
			1 k to 5 k	1.00 + 0.1
	3.000000 A	10 μ V	10 to 1 k	0.3 + 0.06
			1 k to 5 k	1.5 + 0.15
	10.000000 A	10 μ V	10 to 1 k	0.5 + 0.12
			1 k to 5 k	2.5 + 0.2

[1] Specifications are for 2-hour warm-up condition, 6 1/2 digits and they're relative to calibration standards.

[2] 20% over range on all ranges except 750Vac range.

[4] The Range 750Vac is limited to 100kHz.

[5] Specifications are for sine wave input >5% of range. (3 Hz Bandwidth)

Capacitance Characteristics Accuracy \pm (% of reading + % of range) [1]

Function	Range	Test Current	1 Year (23°C \pm 5°C)
Capacitance [6]	1 nF	10 μ A	2.0+0.80
	10 nF	10 μ A	1.0+0.50
	100 nF	100 μ A	1.0+0.50
	1 μ F	100 μ A	1.0+0.50
	10 μ F	100 μ A	1.0+0.50
	100 μ F	1 mA	1.0+0.50
	1 mF	1 mA	1.0+0.50
	10 mF	1 mA	2.0+0.50

[1] Specifications are for 2-hour warm-up condition, 6 1/2 digits and they're relative to calibration standards.

[6] The Null function must be used.

Thermocouple Characteristics [1]

Function	Type	Range	1 Year (23°C \pm 5°C)
Thermocouple [7]	B	600°C to 1820°C	1.5°C
	C	0°C to 2316°C	1.5°C
	E	-250°C to 1000°C	1.5°C
	J	-210°C to 1200°C	1.0°C
	K	-200°C to 1372°C	1.0°C
	N	-200°C to 1300°C	1.0°C
	R	0°C to 1767°C	1.5°C
	S	0°C to 1767°C	1.5°C
	T	-250°C to 400°C	1.5°C

[1] Specifications are for 2-hour warm-up condition, 6 1/2 digits and they're relative to calibration standards.

[7] The measurement accuracy excluded the error of test leads.

General Specifications

Item	Limitation & description
Power Supply	100V / 120V / 220V(230V) / 240 V \pm 10%
Power Line Frequency	50/60 Hz \pm 10%
Power Consumption	25 VA max
Operating Temperature	0 °C to 50 °C
Operating Humidity	Maximum relative humidity 80% for temperature up to 31 °C
Storage Temperature	- 10°C to 60°C
Operating Altitude	Up to 2000 m
Bench Dimensions (WxHxD)	214.6 mm x 88.6 mm x 280.7 mm
Weight	Approx. 2.7 kg
Safety	EN61010-1:2010(3 rd Edition) conformity
EMC	EN61326-1:2013 conformity
Accessories	Power cable, USB cable, Test leads, Fuse, CD-ROM(Application & Instruction manual)

※Note: Regarding the Safety, the LO jack is marked with 500Vpk against ground and SENSE HI to LO is only marked with 200Vpk. The maximum voltage from HI to LO is 1000V.

B. Remote Interface Reference

B.1 An Introduction to the SCPI Language

SCPI (*Standard Commands for Programmable Instruments*) is an ASCII-based instrument command language designed for test and measurement instruments.

SCPI commands are based on a hierarchical structure, also known as a *tree system*. In this system, associated commands are grouped together under a common node or root, thus forming *subsystems*. A portion of the SENSE subsystem is shown below to illustrate the tree system.

[SENSe:]

VOLTage:

DC:RANGe {<range>|MINimum|MAXimum}

VOLTage:

DC:RANGe? [MINimum|MAXimum]

FREQuency:

VOLTage:RANGe {<range>|MINimum|MAXimum}

FREQuency:

VOLTage:RANGe? [MINimum|MAXimum]

DETEctor:

BANDwidth {3|20|200|MINimum|MAXimum}

DETEctor:

BANDwidth? [MINimum|MAXimum]

ZERO:

AUTO {OFF|ONCE|ON}

ZERO:

AUTO?

SENSe is the root keyword of the command, VOLTage and FREQuency are second-level keywords, and DC and VOLTage are third-level keywords. A *colon* (:) separates a command keyword from a lower-level keyword.

Command Format Used in This Manual

The format used to show commands in this manual is shown below:

VOLTage:DC:RANGe {<range>|MINimum|MAXimum}

The command syntax shows most commands (and some parameters) as a mixture of upper- and lower-case letters. The upper-case letters indicate the abbreviated spelling for the command. For shorter program lines, send the abbreviated form. For better program readability, send the long form. For example, in the above syntax statement, VOLT and VOLTAGE are both acceptable forms. You can use upper- or lower-case letters. Therefore, VOLTAGE, volt, and Volt are all acceptable. Other forms, such as VOL and VOLTAG, will generate an error. *Braces* ({ }) enclose the parameter choices for a given command string. The braces are not sent with the command string. A *vertical bar* (|) separates multiple parameter choices for a given command string. *Triangle brackets* (< >) indicate that you must specify a value for the enclosed parameter. For example, the above syntax statement shows the *range* parameter enclosed in triangle brackets. The brackets are not sent with the command string. You must specify a value for the parameter (such as "VOLT:DC:RANG 10"). Some parameters are enclosed in *square brackets* ([]). The brackets indicate that the parameter is optional and can be omitted. The brackets are not sent with the command string. If you do not specify a value for an optional parameter, the multimeter chooses a default value.

Using the *MIN* and *MAX* Parameters

You can substitute MINimum or MAXimum in place of a parameter for many commands. For example, consider the following command:

VOLTage:DC:RANGe {<range>|MINimum|MAXimum}

Instead of selecting a specific voltage range, you can substitute MIN to set the range to its minimum value or MAX to set the range to its maximum value.

Querying Parameter Settings

You can query the current value of most parameters by adding a question mark (?) to the command. For example, the following command sets the sample count to 10 readings:

"SAMP:COUN 10"

You can query the sample count by executing:

"SAMP:COUN?"

You can also query the minimum or maximum count allowed as follows:

"SAMP:COUN? MIN"

"SAMP:COUN? MAX"

※ Note: If you send two query commands without reading the response from the first, and then attempt to read the second response, you may receive some data from the first response followed by the complete second response. To avoid this, do not send a query command without reading the response. When you cannot avoid this situation, send a device clear before sending the second query command.

SCPI Command Terminators

A command string sent to the multimeter must terminate with a <new line> character. The IEEE-488 EOI (end-or-identify) message is interpreted as a <new line> character and can be used to terminate a command string in place of a <new line> character. A <carriage return> followed by a <new line> is also accepted. Command string termination will always reset the current SCPI command path to the root level.

IEEE-488.2 (GPIB) Common Commands

The IEEE-488.2 standard defines a set of common commands that perform functions like reset, self-test, and status operations. Common commands always begin with an asterisk (*), are four to five characters in length, and may include one or more parameters. The command keyword is separated from the first parameter by a blank space.

Use a semicolon (;) to separate multiple commands as shown below:

"*RST; *CLS; *ESE 32; *OPC?"

SCPI Parameter Types

The SCPI language defines several different data formats to be used in program messages and response messages.

Numeric Parameters Commands that require numeric parameters will accept all commonly used decimal representations of numbers including optional signs, decimal points, and scientific notation. Special values for numeric parameters like MINimum, MAXimum, and DEFault are also accepted. You can also send engineering unit suffixes with numeric parameters (e.g., M, k, or μ). If only specific numeric values are accepted, the multimeter will automatically round the input numeric parameters. The following command uses a numeric parameter:

VOLTage:DC:RANGe {<range>|MINimum|MAXimum}

Discrete Parameters Discrete parameters are used to program settings that have a limited number of values (like BUS, IMMEDIATE, EXTERNAL). They have a short form and a long form just like command keywords. You can mix upper-and lower-case letters. Query responses will always return the short form in all upper-case letters. The following command uses discrete parameters:

TRIGger:SOURce {BUS|IMMEDIATE|EXTERNAL}

Boolean Parameters Boolean parameters represent a single binary condition that is either true or false. For a false condition, the multimeter will accept "OFF" or "0". For a true condition, the multimeter will accept "ON" or "1". When you query a boolean setting, the instrument will always return "0" or "1". The following command uses a boolean parameter:

VOLTage:DC:RANGe:AUTO {OFF|ON}

String Parameters String parameters can contain virtually any set of ASCII characters. A string must begin and end with matching a double quote. You can include the quote delimiter as part of the string by typing it twice without any characters in between. The following command uses a string parameter:

DISPlay:TEXT <quoted string>

B.2 Output Data Formats

Output data will be in one of formats shown in the table below.

Type of Output Data

Non-reading queries

Single reading (IEEE-488, RS-232C)

Multiple readings (IEEE-488, RS-232C)

Output Data Format

< 80 ASCII character string

SD.DDDDDDDDESDD<nl>

SD.DDDDDDDDESDD,...,<nl>

SD.DDDDDDDDESDD<cr><nl>

SD.DDDDDDDDESDD,...,<cr><nl>

S Negative sign or positive sign

D Numeric digits

E Exponent

<nl> newline character

<cr> carriage return character

B.3 The MEASure? Command

MEASure:VOLTage:DC? {<range>|MIN|MAX|DEF},{<resolution>|MIN|MAX|DEF}

Preset and make a dc voltage measurement with the specified range and resolution. The reading is sent to the output buffer.

MEASure:VOLTage:DC:RATio?

{<range>|MIN|MAX|DEF},{<resolution>|MIN|MAX|DEF}

Preset and make a dc:dc ratio measurement with the specified range and resolution. The reading is sent to the output buffer. For ratio measurements, the specified range applies to input signal, yet autorange is selected for the reference signal.

MEASure:VOLTage:AC? {<range>|MIN|MAX|DEF},{<resolution>|MIN|MAX|DEF}

Preset and make an AC voltage measurement with the specified range and resolution. The reading is sent to the output buffer. For AC measurement, resolution is fixed at 6 ½ digits. Therefore the resolution parameter only affects the front panel display.

MEASure:CURRent:DC? {<range>|MIN|MAX|DEF},{<resolution>|MIN|MAX|DEF}

Preset and make a dc current measurement with the specified range and resolution. The reading is sent to the output buffer.

MEASure:CURRent:AC? {<range>|MIN|MAX|DEF},{<resolution>|MIN|MAX|DEF}

Preset and make a AC current measurement with the specified range and resolution. The reading is sent to the output buffer. For AC measurement, resolution is fixed at 6 ½ digits. Therefore the resolution parameter only affects the front panel display.

MEASure:RESistance? {<range>|MIN|MAX|DEF},{<resolution>|MIN|MAX|DEF}

Preset and make a 2-wire Ω measurement with the specified range and resolution. The reading is sent to the output buffer.

MEASure:FRESistance? {<range>|MIN|MAX|DEF},{<resolution>|MIN|MAX|DEF}

Preset and make a 4-wire Ω measurement with the specified range and resolution. The reading is sent to the output buffer.

MEASure:FREQuency? {<range>|MIN|MAX|DEF},{<resolution>|MIN|MAX|DEF}

Preset and make a frequency measurement with the specified range and resolution. The reading is sent to the output buffer. For frequency measurements, the meter uses only one "range" for all inputs between 3Hz and 300kHz. With no input signal applied, frequency measurements return "0".

MEASure:PERiod? {<range>|MIN|MAX|DEF},{<resolution>|MIN|MAX|DEF}

Preset and make a period measurement with the specified range and resolution. The reading is sent to the output buffer. For period measurements, the meter uses only one "range" for all inputs between 0.33 seconds and 3.3 μ sec. With no input signal applied, period measurements return "0".

MEASure:CONTinuity?

Preset and make a continuity measurement. The reading is sent to the output buffer. The range and resolution are fixed at 1k Ω and 5 ½ digits respectively.

MEASure:DIODE?

Preset and make a diode measurement. The reading is sent to the output buffer. The range and resolution are fixed at 1Vdc with 1mA current source and 5 ½ digits respectively.

MEASure:TEMPerature?

Preset and make a temperature measurement with RTD. The reading is sent to the output buffer.

MEASure:TCouple?

Preset and make a temperature measurement with thermocouple. The reading is sent to the output buffer.

B.4 The CONFigure Command

CONFigure:VOLTage:DC {<range>|MIN|MAX|DEF},{<resolution>|MIN|MAX|DEF}

Preset and configure the multimeter for DC voltage measurements with the specified range and resolution. This command does not initiate the measurement.

CONFigure:VOLTage:DC:RATio

{<range>|MIN|MAX|DEF},{<resolution>|MIN|MAX|DEF}

Preset and configure the multimeter for DC:DC ratio measurements with the specified range and resolution. This command does not initiate the measurement. The specified range applies to the source signal and autorange is selected for the reference signal.

CONFigure:VOLTage:AC {<range>|MIN|MAX|DEF},{<resolution>|MIN|MAX|DEF}

Preset and configure the multimeter for AC voltage measurements with the specified range and resolution. This command does not initiate the measurement. For AC measurement, resolution is fixed at 6½ digits. Therefore the resolution parameter only affects the front panel display.

CONFigure:CURRent:DC {<range>|MIN|MAX|DEF},{<resolution>|MIN|MAX|DEF}

Preset and configure the multimeter for DC current measurements with the specified range and resolution. This command does not initiate the measurement.

CONFigure:CURRent:AC {<range>|MIN|MAX|DEF},{<resolution>|MIN|MAX|DEF}

Preset and configure the multimeter for AC current measurements with the specified range and resolution. This command does not initiate the measurement. For AC measurement, resolution is fixed at 6½ digits. Therefore the resolution parameter only affects the front panel display.

CONFigure:RESistance {<range>|MIN|MAX|DEF},{<resolution>|MIN|MAX|DEF}

Preset and configure the multimeter for 2-wire Ω measurements with the specified range and resolution. This command does not initiate the measurement.

CONFigure:FRESistance {<range>|MIN|MAX|DEF},{<resolution>|MIN|MAX|DEF}

Preset and configure the multimeter for 4-wire Ω measurements with the specified range and resolution. This command does not initiate the measurement.

CONFigure:FREQuency {<range>|MIN|MAX|DEF},{<resolution>|MIN|MAX|DEF}

Preset and configure the multimeter for frequency measurements with the specified range and resolution. This command does not initiate the measurement. For frequency measurements, the meter uses only one "range" for all inputs between 3Hz and 300kHz. With no input signal applied, frequency measurements return "0".

CONFigure:PERiod {<range>|MIN|MAX|DEF},{<resolution>|MIN|MAX|DEF}

Preset and configure a period measurement with the specified range and resolution. This command does not initiate the measurement. For period measurements, the meter uses only one "range" for all inputs between 0.33 seconds and 3.3 μ sec. With no input signal applied, period measurements return "0".

CONFigure:CONTInuity

Preset and configure for a continuity measurement. This command does not initiate the measurement. The range and resolution are fixed at 1kΩ and 5½ digits respectively.

CONFigure:DIODE

Preset and configure for a diode measurement. This command does not initiate the measurement. The range and resolution are fixed at 1Vdc with 1mA current source and 5½ digits respectively.

CONFigure:TEMPerature

Preset and configure for a RTD measurement. This command does not initiate the measurement. The resolution is fixed at 6½ digits.

CONFigure:TCouple

Preset and configure for a thermocouple measurement. This command does not initiate the measurement. The resolution is fixed at 6½ digits.

CONFigure?

Query a recent condition of function, and return a quoted string.

B.5 The Measurement Configuration Command

[SENSe:]FUNctIon "<function>"

Select a measurement function and enclose it in quotes in the command string (FUNC "VOLT:DC"). Use one of the following strings.

VOLTage:DC	FREQuency
VOLTage:DC:RATio	PERiod
VOLTage:AC	CONTInuity
CURRent:DC	DIODE
CURRent:AC	TCouple
RESistance (for 2-wire ohms)	TEMPerature
FRESistance (for 2-wire ohms)	CAPacitance

[SENSe:]FUNctIon?

Query the measurement function and return a quoted string.

[SENSe]:FUNctIon[1/2] "<function>"

Sets DMM to the measurement function listed in the function parameter. The function must be enclosed in quotes in the command string (FUNC "VOLT:DC") for Example. In addition, Parameters [1/2] means that use 1 for primary display, and 2 for secondary display. The followings are the valid commands.

※ Note: Using FUNC without a 1 or 2 will default to 1 for the primary display.

[SENSE:] FUNCTION[1/2] "VOLTage:DC"
 [SENSE:] FUNCTION[1/2] "VOLTage:AC"
 [SENSE:] FUNCTION[1/2] "CURRent:DC"
 [SENSE:] FUNCTION[1/2] "CURRent:AC"
 [SENSE:] FUNCTION[1/2] "FREQuency"
 [SENSE:] FUNCTION[1/2] "PERiod"
 [SENSE:] FUNCTION[1/2] "FREQuency:CURR"
 [SENSE:] FUNCTION[1/2] "PERiod:CURR"
 [SENSE:] FUNCTION[1/2] "RESistance"
 [SENSE:] FUNCTION[1/2] "FRESistance"
 [SENSE:] FUNCTION[1/2] "CAPacitance"
 [SENSE:] FUNCTION[1/2] "TEMPerature"
 [SENSE:] FUNCTION[1/2] "TCouple"
 [SENSE:] FUNCTION[1/2]? (※ Note: Query measurement function)
 [SENSE:] FUNCTION[1/2] "NONE" (※ Note: Turn off secondary display and it's valid only when used with FUNC2.)

[SENSe:]<function>:RANGe {<range>|MINimum|MAXimum}

Select a range for the selected function. For frequency and period measurements, range applies to the signal's input voltage, not its frequency (use FREQuency:VOLTage or PERiod:VOLTage). MIN selects the lowest range for the selected function. MAX selects the highest range.

[SENSe:]<function>:RANGe? [MINimum|MAXimum]

Query the range for the selected function. For frequency and period, use FREQuency:VOLTage or PERiod:VOLTage. Autorange thresholds: Down range at <10% of range; Up range at >120% of range.

[SENSe:]<function>:RANGe:AUTO {OFF|ON}

Disable or enable autorange for the selected function.

[SENSe:]<function>:RANGe:AUTO?

Query the autorange setting. Return "1" (ON) or "0" (OFF).

[SENSe:]<function>:RESolution {<resolution>|MINimum|MAXimum}

Set resolution for the selected function (not valid for frequency, period, or ratio). Specify the resolution in the same units as the measurement function, not in number of digits. MIN selects the smallest value accepted, which gives the most resolution. MAX selects the largest value accepted which gives the least resolution.

[SENSe:]<function>:RESolution? [MINimum|MAXimum]

Query the resolution for the selected function.

[SENSe:]UNIT {Cel|Far|K}

Select units for temperature measurement. Cel means Celsius, Far means Fahrenheit, and K means Kelvin.

[SENSe:]UNIT?

Query units for temperature measurement.

[SENSe:]TCouple:TYPE {B|C|E|J|K|N|R|S|T}

Select thermocouple sensor type.

[SENSe:]TCouple:TYPE?

Query thermocouple sensor type.

[SENSe:]TCouple:RJUNction:RSElect {REAL|SIMulated }

Select a reference junction type, real or simulated.

[SENSe:]TCouple:RJUNction:RSElect?

Query the reference junction type, real or simulated.

[SENSe:]TCouple:RJUNction:SIMulated {<value>|MINimum|MAXimum}

Set the default temperature of the simulated reference junction.

[SENSe:]TCouple:RJUNction:SIMulated?

Query the default temperature of the simulated reference junction.

[SENSe:]TCouple:RJUNction:REAL:OFFSet {<value>|MINimum|MAXimum}

Set the offset voltage of the real reference junction.

[SENSe:]TCouple:RJUNction:REAL:OFFSet? [MINimum|MAXimum]

Query the offset voltage of the real reference junction.

[SENSe:]TEMPerature:RTD:TYPE

{PT100|D100|F100|PT385|PT3916|USER|SPRTD|NTCT}

Select the RTD type for temperature measurement with RTD.

[SENSe:]TEMPerature:RTD:TYPE?

Query the RTD type for temperature measurement with RTD.

[SENSe:]TEMPerature:RTD:RZERo {<value>|MINimum|MAXimum}

Set the R-Zero constant for the user defined RTD type.

[SENSe:]TEMPerature:RTD:RZERo? [MINimum|MAXimum]

Query the R-Zero constant for the user defined RTD type.

[SENSe:]TEMPerature:RTD:ALPHA {<value>|MINimum|MAXimum}

Set the alpha constant for the user type.

[SENSe:]TEMPerature:RTD:ALPHA? [MINimum|MAXimum]

Query the alpha constant for the user type.

[SENSe:]TEMPerature:RTD:BETA {<value>|MINimum|MAXimum}

Set the beta constant for the user type.

[SENSe:]TEMPerature:RTD:BETA? [MINimum|MAXimum]

Query the beta constant for the user type.

[SENSe:]TEMPerature:RTD:DELTA {<value>|MINimum|MAXimum}

Set the delta constant for the user type.

[SENSe:]TEMPerature:RTD:DELTA? [MINimum|MAXimum]

Query the delta constant for the user type.

[SENSe:]TEMPerature:SPRTD:RZERO {<value>|MINimum|MAXimum}

Set the sensor R value at 0 degree Celsius.

[SENSe:]TEMPerature:SPRTD:RZERO? [MINimum|MAXimum]

Query the sensor R value at 0 degree Celsius.

[SENSe:]TEMPerature:SPRTD:A4 {<value>|MINimum|MAXimum}

Set the A4 coefficient.

[SENSe:]TEMPerature:SPRTD:A4? [MINimum|MAXimum]

Query the A4 coefficient.

[SENSe:]TEMPerature:SPRTD:B4 {<value>|MINimum|MAXimum}

Set the B4 coefficient.

[SENSe:]TEMPerature:SPRTD:B4? [MINimum|MAXimum]

Query the B4 coefficient.

[SENSe:]TEMPerature:SPRTD:AX {<value>|MINimum|MAXimum}

Set the A coefficient.

[SENSe:]TEMPerature:SPRTD:AX? [MINimum|MAXimum]

Query the A coefficient.

[SENSe:]TEMPerature:SPRTD:BX {<value>|MINimum|MAXimum}

Set the B coefficient.

[SENSe:]TEMPerature:SPRTD:BX? [MINimum|MAXimum]

Query the B coefficient.

[SENSe:]TEMPerature:SPRTD:CX {<value>|MINimum|MAXimum}

Set the C coefficient.

[SENSe:]TEMPerature:SPRTD:CX? [MINimum|MAXimum]

Query the C coefficient.

[SENSe:]TEMPerature:SPRTD:DX {<value>|MINimum|MAXimum}

Set the D coefficient.

[SENSe:]TEMPerature:SPRTD:DX? [MINimum|MAXimum]

Query the D coefficient.

[SENSe:]TEMPerature:TRANsducer FRTD

Set the RTD Measurement to 4-Wire.

[SENSe:]TEMPerature:TRANsducer RTD

Set the RTD Measurement to 2-Wire.

[SENSe:]<function>:NPLCycles

{0.001|0.006|0.02|0.06|0.2|0.6|1|2|10|100|MINimum|MAXimum}

Set the integration time in number of power line cycles for the selected function. This command is valid only for DCV, DCI, 2-wire ohms and 4-wire ohms.

[SENSe:]<function>:NPLCycles? [MINimum|MAXimum]

Query the integration time for the selected function.

[SENSe:]FREQuency:APERture {0.01|0.1|1|MINimum|MAXimum}

Set the gate time (or aperture time) for frequency function. Specify 10 ms (4 1/2 digits), 100 ms (default; 5 1/2 digits), or 1 second (6 1/2 digits).

[SENSe:]FREQuency:APERture? [MINimum|MAXimum]

Query the gate time (or aperture time) for frequency function.

[SENSe:]PERiod:APERture{0.01|0.1|1|MINimum|MAXimum}

Set the gate time (or aperture time) for period function. Specify 10 ms (4 1/2 digits), 100 ms (default; 5 1/2 digits), or 1 second (6 1/2 digits).

[SENSe:]PERiod:APERture? [MINimum|MAXimum]

Query the gate time (or aperture time) for period function.

[SENSe:]DETector:BANDwidth {3|20|200|MINimum|MAXimum}

Specify the lowest frequency expected in the input signal. The meter selects the slow, medium or fast ac filter based on the frequency you specify.

[SENSe:]DETector:BANDwidth? [MINimum|MAXimum]

Query the ac filter and return the bandwidth.

[SENSe:]ZERO:AUTO {OFF|ONCE|ON}

Disable or enable the auto zero mode. The OFF and ONCE have a similar effect. OFF mode does not issue a new offset measurement until the multimeter goes to the "WAIT-FOR-TRIGGER" state. Parameter ONCE issues an immediate offset measurement.

[SENSe:]ZERO:AUTO?

Query the auto zero mode. Returns "1" (ON) or "0" (OFF or ONCE).

B.6 The Math Operation Command

CALCulate:FUNction {PERCent|AVERage|NULL|LIMit|MXB|DB|DBM}

Select the math function. Only one function can be enabled at a time. The default function is percent.

CALCulate:FUNction?

Query the present math function. Returns PERC, AVER, NULL, LIM, MXB, DB or DBM.

CALCulate:STATe {OFF|ON}

Disable or enable the selected math function.

CALCulate:STATe?

Query the state of the math function. Returns "0"(OFF) or "1"(ON).

CALCulate:PERCent:TARGeT {<value>|MINimum|MAXimum}

Set the target value for percent math function. The multimeter clears the value when Min/Max is turned on, when the power has been off or a remote interface reset.

CALCulate:PERCent:TARGeT? [MINimum|MAXimum]

Query the target value for percent math function.

CALCulate:AVERage:MINimum?

Read the minimum value found during the Min/Max operation. The multimeter clears the value when Min/Max is turned on, when the power has been off or a remote interface reset.

CALCulate:AVERage:MAXimum?

Read the maximum value found during the Min/Max operation. The multimeter clears the value when Min/Max is turned on, when the power has been off or a remote interface reset.

CALCulate:AVERage:AVERage?

Read the average value of all readings taken since the Min/Max operation has been enabled. The multimeter clears the value when Min/Max is turned on, when the power has been off or a remote interface reset.

CALCulate:AVERage:COUNT?

Read the number of readings taken since Min/Max has been enabled. The multimeter clears the value when Min/Max is turned on, when the power has been off or a remote interface reset.

CALCulate:NULL:OFFSet {<value>|MINimum|MAXimum}

Store a null value in the multimeter's Null Register. *You must turn on the math operation before writing to the math register.* You can set the null value to any number between 0 and $\pm 120\%$ of the highest range.

CALCulate:NULL:OFFSet?

Query the null value.

CALCulate:LIMit:LOWer {<value>|MINimum|MAXimum}

Set the lower limit for limit testing. You can set the value to any number from 0 to $\pm 120\%$ of the highest range, for the present function.

CALCulate:LIMit:LOWer?

Query the lower limit for the limit testing.

CALCulate:LIMit:UPPer {<value>|MINimum|MAXimum}

Set the upper limit for limit testing. You can set the value to any number from 0 to $\pm 120\%$ of the highest range, for the present function.

CALCulate:LIMit:UPPer?

Query the upper limit for the limit testing.

CALCulate:MXB:MMFactor {<value>|MINimum|MAXimum}

Set the value of M.

CALCulate:MXB:MMFactor? [MINimum|MAXimum]

Query the value of M.

CALCulate:MXB:MBFactor {<value>|MINimum|MAXimum}

Set the value of B.

CALCulate:MXB:MBFactor? [MINimum|MAXimum]

Query the value of B.

CALCulate:DB:REference {<value>|MINimum|MAXimum}

Store a relative value in the dB Relative Register. *You must turn on the math operation before writing to the math register.* You can set the relative value to any number between 0 dBm and ± 200 dBm.

CALCulate:DB:REFerence? [MINimum|MAXimum]

Query the dB relative value.

CALCulate:DBM:REFerence {<value>|MINimum|MAXimum}

Set the dBm reference value. Choose from: 50 ~ 8000 ohms.

CALCulate:DBM:REFerence? [MINimum|MAXimum]

Query the dBm reference value.

DATA:FEED RDG_STORE,{“CALCulate”|“”}

Selects whether readings taken using the INITiate command are stored in the multimeter’s internal memory (default) or not stored at all. In the default state (DATA:FEED RDG_STORE,“CALC”), up to 2000 readings are stored in memory when INITiate is executed. The MEASure? And CONFigure commands automatically select “CALC”. With memory disabled (DATA:FEED RDG_STORE,“”), readings taken using INITiate are not stored. This may be useful with the Min/Max operation since it allows you to determine an average of the readings without storing the individual values. An error will be generated if you attempt to transfer readings to the output buffer using the FETCh? command.

DATA:FEED?

Query the reading memory state. Return “CALC” or “”.

B.7 The Triggering Commands

INITiate

Change the state of the triggering system from the “idle” state to “wait-for-trigger” state. The meter will start to make measurements when a required triggering condition is met after the INITiate command is received. Readings are stored in memory until you are ready to read them. Use FETCh? command to retrieve your measurements results.

READ?

Change the state of the triggering system from the “idle” state to “wait-for-trigger” state. The meter will start to make measurements when a required triggering condition is met after the READ? Command is received. Readings are sent to the output buffer right away.

TRIGger:SOURce {BUS|IMMediate|EXTernal}

Select a trigger source. The multimeter will accept a software (BUS) trigger, an immediate internal trigger, or a hardware trigger from the rear-panel EXT TRIG terminal.

TRIGger:SOURce?

Query the trigger source.

TRIGger:DElay {<seconds>|MINimum|MAXimum}

Set a trigger delay time in seconds. The delay is the time between the trigger signal and each sample that follows. Specify a delay time from 0 to 3600 seconds.

TRIGger:DElay?

Query the trigger delay time.

TRIGger:DElay:AUTO {OFF|ON}

Disable or enable a automatic trigger delay. The delay is determined by function, range, integration time, and ac filter setting. Specifying a delay time automatically turns off the automatic trigger delay.

TRIGger:DElay:AUTO?

Query the automatic trigger delay mode. Returns "0" (OFF) or "1" (ON).

SAMple:COUNT {<value>|MINimum|MAXimum}

Set the number of readings (samples) the multimeter takes per trigger. Select a number from 1 to 50,000 readings per trigger.

SAMple:COUNT ? [MINimum|MAXimum]

Query the sample count.

TRIGger:COUNT {<value>|MINimum|MAXimum|INFinite}

Specify the number of triggers the multimeter will accept before returning to the "idle" state. Select from 1 to 50,000 triggers. The INFinite parameter instructs the multimeter to take triggers continuously. Trigger count is ignored while in local operation.

TRIGger:COUNT? [MINimum|MAXimum|INFinite]

Query the trigger count. Returns "9.90000000E+37" when you select the infinite trigger count.

B.8 The System-Related Commands

FETCh?

Transfer readings stored in memory by the INITiate command to output buffer where you are able to read them into your bus controller.

READ?

Change the state of the triggering system from the "idle" state to "wait-for-trigger" state. The meter will start to make measurements when a required triggering condition is met after the READ? command is received. Measurement readings are sent to the output buffer immediately.

DISPlay {OFF|ON}

Turn off or on the display.

DISPlay?

Query the display setting. Returns "0" (OFF) or "1" (ON).

DISPlay:TEXT <quoted string>

Show a message on the front panel display. The allowed message can be up to 16 characters in the lower row display; any additional characters will be truncated.

DISPlay:TEXT?

Query the message sent to the front panel display.

DISPlay:TEXT:CLEAr

Clear the message shown on the front panel display.

SYSTem:BEEPer

Issue a single beeping tone.

SYSTem:BEEPer:STATe {OFF|ON}

Disable or enable the beeper.

SYSTem:BEEPer:STATe?

Query the beeper mode. Returns "0" (OFF) or "1" (ON).

SYSTem:ERRor?

Query the multimeter's error queue. Up to 20 errors can be stored in the queue. Errors are retrieved in first-in-first-out (FIFO) order. Each error string may contain up to 80 characters.

SYSTem:VERSion?

Query the present SCPI version.

L0

Set to the default identification string.

L1

Set to the compatible identification string.

DATA:POINTs?

Query the number of readings stored in the multimeter's internal memory.

***RST**

Reset the multimeter to the power-on configuration. This command cannot clear the error queue.

***IDN?**

Read the multimeter's identification string (be sure to dimension a string variable with at least 35 characters).

Other Interface Commands**SYSTem:LOCal**

Place the multimeter in the *local* mode. All buttons on the front panel are fully functional.

SYSTem:REMOte

Place the multimeter in the *remote* mode. All buttons on the front panel, except the LOCAL button, are disabled.

B.9 The SCPI Status Reporting

Status registers provide the status mechanism described in IEEE488.2. And there are three register groups with various equipment conditions recorded by the status system. They are the Status Byte Register, the Standard Event Register and the Questionable Data Register. The Status Byte Register collects and records high-level summary information which is reported in other register groups. With the following diagram illustration, users would make themselves clear for the SCPI status system.

In addition, the Standard Event and the Questionable Data Registers have event registers which belong to read-only registers and report defined conditions in a multimeter. Bits are latched in the event registers. As long as an event bit is set, subsequent state changes will be ignored. To query an event register will return a decimal value corresponding to binary-weighted sum of all bits set in the register.

An enable register is readable and writable, and can define which bits in the corresponding event register are ORed together to generate a single summary bit. To query an enable register won't clear it, as well the command *CLS, but it can clear the bits in the event registers. Moreover, to enable bits in an enable register, users have to write a decimal value corresponding to the binary-weighted sum of the bits in the register by their demands.

Binary Weights

$2^0 = 1$	$2^8 = 256$
$2^1 = 2$	$2^9 = 512$
$2^2 = 4$	$2^{10} = 1024$
$2^3 = 8$	$2^{11} = 2048$
$2^4 = 16$	$2^{12} = 4096$
$2^5 = 32$	$2^{13} = 8192$
$2^6 = 64$	$2^{14} = 16384$
$2^7 = 128$	$2^{15} = 32768$

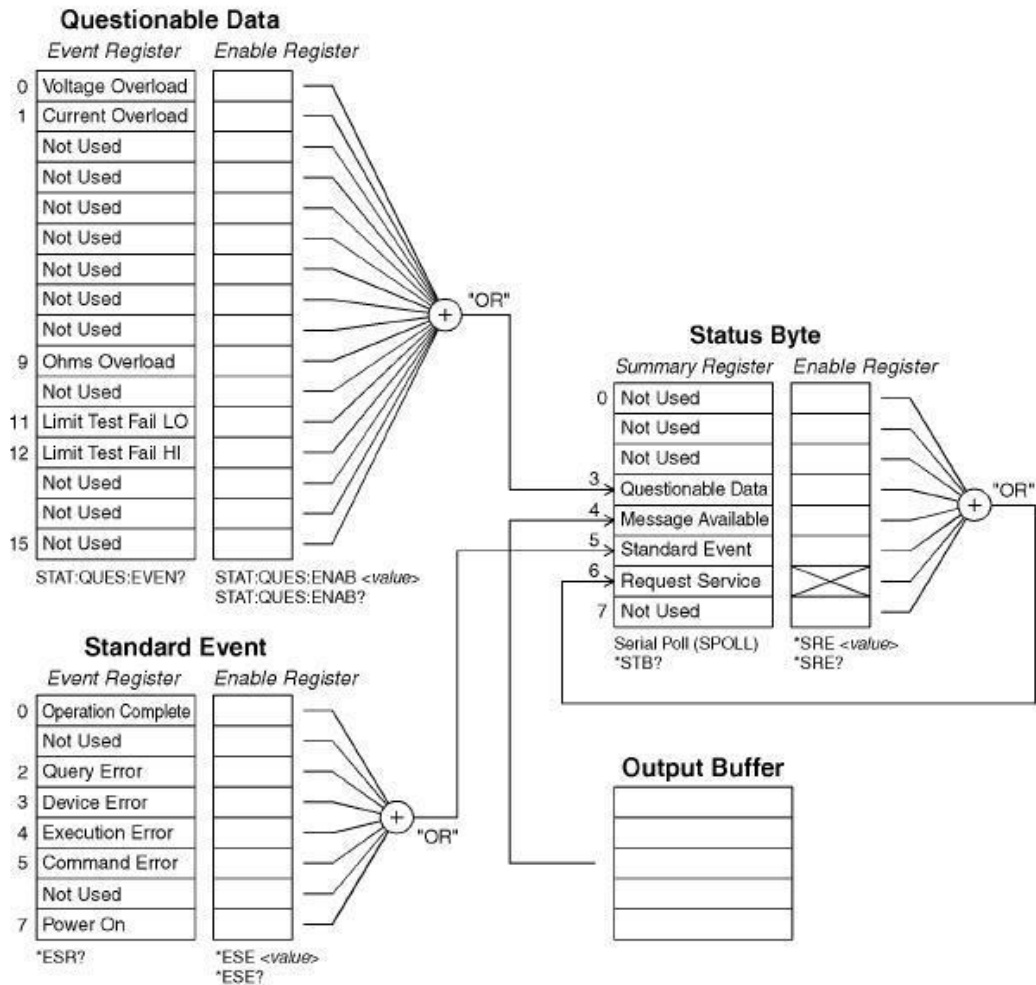

About the Status Byte

The conditions from other status registers will be reported by the status byte summary register. To clear an event register will clear the according bits in the status byte summary register. And to read all messages in the output buffer, including all pending queries, will clear the message available bit. The following list shows the definition of each bit.

Bit	Decimal Value	Definition
0. Not Used	1	Set to 0.
1. Not Used	2	Set to 0.
2. Not Used	4	Set to 0.
3. Questionable Data	8	One or more bits are set in the questionable data register (Bits have to be "enabled" in enable register).
4. Message Available	16	Data in the DMM's output buffer is available.
5. Standard Event	32	One or more bits are set in the Standard Event Register (Bits have to be "enabled" in enable register).
6. Request Service	64	The DMM is requiring service (Serial Poll).
7. Not Used	128	Set to 0.

On the other hand, there are some conditions that users have to note.

The following conditions will clear the summary register.

- Users execute a *CLS (clear status) command.
- To query the standard event and questionable data registers will clear only the separate bits in the summary register.

The following conditions will clear the enable register.

- Users turn on the power, and have set the DMM previously by using the *PSC 1 command.
- Users execute a *SRE 0 command.

※ Note: If you have set the DMM previously by using *PSC 0, the status byte enable register won't be cleared at power-on.

About the Standard Event Register

The standard event register reports the instrument event types below, such as power-on detected, command syntax errors, command execution errors, self-test (calibration errors), query errors or the moment of executing an *OPC command. Then through the enable register, all conditions will be reported in the standard event summary bit. At the moment, users have to write a decimal value by using the *ESE command to set the enable register mask.

※ Note 1: The errors in the DMM's error queue except reading the error queue by using SYSTem:ERRor? will be recorded by an error condition (including bits 2, 3, 4 or 5 of the standard event register).

※ Note 2: In both the standard event register bit 3 and the questionable data event register bits 0, 1 or 9, a reading overload condition can be reported all the time. But in the DMM's error queue, no error message will be recorded.

Bit Definitions for Standard Event Register

Bit	Decimal Value	Definition
0. Operation Complete	1	All commands prior to and including an *OPC command have been executed
1. Not Used	2	Set to 0.
2. Query Error	4	The DMM output buffer was empty as the DMM tried to read from it. Or a new command line was received before a previous query has been read. Or, both the input and output buffers are full.
3. Device Error	8	Error occurrence from a self-test, calibration or reading overload.
4. Execution Error	16	Error occurrence from an execution.
5. Command Error	32	Error occurrence from a command's syntax.
6. Not Used	64	Set to 0.
7. Power On	128	Since the last time the event register was read or cleared, power has been turned off and on.

The following conditions will clear the standard event register.

- Users send a *CLS command.
- Users query the event register by using the *ESR? command.

The following conditions will clear the standard event enable register.

- Users turn on the power, and have set the DMM previously by using the *PSC 1 command.
- Users execute a *ESE 0 command.

※ Note 1: When the DMM is powered on, the standard event enable register won't be cleared if users have set the DMM previously by using *PSC 0.

※ Note 2: The reset command (*RST) or device clear in event registers won't clear bits.

About the Questionable Data Register

The questionable data register reports the quality of the DMM's measurement results, as well overload conditions and high/low limit test results. Through the enable register, all of the conditions can be reported in the questionable data summary bit. At the moment, users have to write a decimal value by using the STATus:QUESTionable:ENABle command to set the enable register mask.

Bit Definitions for Questionable Data Register

Bit	Decimal Value	Definition
0. Voltage Overload	1	Range overload on dc/ac volts, frequency, period, diode or ratio function
1. Current Overload	2	Range overload on dc/ac current function.
2. Not Used	4	Set to 0
3. Not Used	8	Set to 0
4. Not Used	16	Set to 0
5. Not Used	32	Set to 0
6. Not Used	64	Set to 0
7. Not Used	128	Set to 0
8. Not Used	256	Set to 0
9. Ohms Overload	512	Range overload on 2-/4-wired ohm function.
10. Not Used	1024	Set to 0
11. Limit Failed at LO	2048	Reading is less than lower limit under limit test.
12. Limit Failed at HI	4096	Reading is excess upper limit under limit test.
13. Not Used	8192	Set to 0
14. Not Used	16384	Set to 0
15. Not Used	32768	Set to 0

The following conditions will clear the questionable data event register.

- Users execute a *CLS command.
- Users query the event register by using STATus:QUESTionable:EVENT?.

The following conditions will clear the questionable data enable register.

- Users turn on the power without using *PSC command.
- Users execute the STATus:PRESet command.
- Users execute the STATus:QUESTionable:ENABle 0 command.

※ Note: The reset command (*RST) or device clear in event registers won't clear bits.

B.10 Status Reporting Commands

SYSTem:ERRor?

Query the multimeter's error queue. Up to 20 errors can be stored in the queue. Errors are retrieved in first-in-first out (FIFO) order. Each error string may contain up to 80 characters.

STATus:QUESTionable:ENABLE <enable value>

Enable bits in the Questionable Data enable register. The selected bits are then reported to the Status Byte.

STATus:QUESTionable:ENABLE?

Query the Questionable Data enable register. The multimeter returns a binary-weighted decimal representing the bits set in the enable register.

STATus:QUESTionable:EVENT?

Query the Questionable Data event register. The multimeter returns a decimal value which corresponds to the binary-weighted sum of all bits set in the register.

STATus:PRESet

Clear all bits in the Questionable Data enable register.

***CLS**

Clear the Status Byte summary register and all event registers.

***ESE <enable value>**

Enable bits in the Standard Event enable register. The selected bits are then reported to the Status Byte.

***ESE?**

Query the Standard Event enable register. The multimeter returns a decimal value which corresponds to the binary-weighted sum of all bits set in the register.

***ESR?**

Query the Standard event register. The multimeter returns a decimal value which corresponds to the binary-weighted sum of all bits set in the register.

***OPC**

Sets the "operation complete" bit (bit 0) in the Standard Event register after the command is executed.

***OPC?**

Returns "1" to the output buffer after the command is executed.

***PSC {0|1}**

Power-on status clear. Clear the Status Byte and Standard Event register enable masks when power is turned on (*PSC 1). When *PSC 0 is in effect, the Status Byte and Standard Event register enable masks are not cleared when power is turned on. [Stored in non-volatile memory]

***PSC?**

Query the power-on status clear setting. Returns "0" (*PSC 0) or "1" (*PSC 1).

***SRE <enable value>**

Enable bits in the Status Byte enable register.

***SRE?**

Query the Status Byte enable register. The multimeter returns a decimal value which corresponds to the binary-weighted sum of all bits set in the register.

***STB?**

Query the Status Byte summary register. The *STB? command is similar to a serial poll but it is processed like any other instrument command. The *STB? command returns the same result as a serial poll but the "request service" bit (bit 6) is not cleared if a serial poll has occurred.

B.11 SCPI Compliance Information

This section encloses a list of commands that are device-specific to the DL-1060. Although not included in the 1999.0 version of the SCPI standard, these commands are designed with the SCPI format in mind and they follow all of the syntax rules of the standard.

Many of the required SCPI commands are accepted by the multimeter but are not described in this manual for simplicity or clarity. Most of these non-documented commands duplicate the functionality of a command already described in this chapter.

MEASure:

CONTInuity?

DIODE?

SAMPlE:

COUNT {<value>|MINimum|MAXimum}

COUNT? [MINimum|MAXimum]

[SENSE:]

FUNCTion "CONTInuity"

FUNCTion "DIODE"

FREQuency:VOLTage:RANGe {<range>|MINimum|MAXimum}

FREQuency:VOLTage:RANGe? [MINimum|MAXimum]

FREQuency:VOLTage:RANGe:AUTO {OFF|ON}

FREQuency:VOLTage:RANGe:AUTO?
PERiod:VOLTage:RANGe {<range>|MINimum|MAXimum}
PERiod:VOLTage:RANGe? [MINimum|MAXimum]
PERiod:VOLTage:RANGe:AUTO {OFF|ON}
PERiod:VOLTage:RANGe:AUTO?
ZERO:AUTO?

CALCulate:

PERCent:TARGet {<value>|MINimum|MAXimum}
PERCent:TARGet? [MINimum|MAXimum]
AVERage:MINimum?
AVERage:MAXimum?
AVERage:AVERage?
AVERage:COUNT?
NULL:OFFSet {<value>|MINimum|MAXimum}
NULL:OFFSet? [MINimum|MAXimum]
LIMit:LOWer {<value>|MINimum|MAXimum}
LIMit:LOWer? [MINimum|MAXimum]
LIMit:UPPer {<value>|MINimum|MAXimum}
LIMit:UPPer? [MINimum|MAXimum]
MXB:MMFactor {<value>|MINimum|MAXimum}
MXB:MMFactor? [MINimum|MAXimum]
MXB:MBFactor {<value>|MINimum|MAXimum}
MXB:MBFactor? [MINimum|MAXimum]
DB:REFerence {<value>|MINimum|MAXimum}
DB:REFerence? [MINimum|MAXimum]
DBM:REFerence {<value>|MINimum|MAXimum}
DBM:REFerence? [MINimum|MAXimum]

CONFigure:

CONTinuity
DIODE

INPut:

IMPedance:AUTO {OFF|ON}
IMPedance:AUTO?

B.12 GP-IB (IEEE-488) Compliance Information

GP-IB Common Commands

*CLS
*ESE <enable value>
*ESE?
*ESR?
*IDN?

*OPC
*OPC?
*PSC {0|1}
*PSC?
*RST
*SRE <enable value>
*SRE?
*STB?
*TRG

Using Device Clear to Halt Measurements

Device clear is an IEEE-488 low-level bus message which can be used to halt measurements in progress. Different programming languages and IEEE-488 interface cards provide access to this capability through their own unique commands. The status registers, the error queue, and all configuration states are left unchanged when a device clear message is received. Device clear performs the following actions.

- All measurements in progress are aborted.
- The multimeter returns to the trigger "idle state."
- The multimeter's input and output buffers are cleared.
- The multimeter is prepared to accept a new command string.

C. About Application Programs

This section provides a brief description for each DL-1060 sample collection.

All of the following programs use the NI-VISA. If you want to modify the example programs, or write your own programs and compile them, you will need to install the NI-VISA.

Visual Basic 6.0® and Visual C++® are registered trademarks of Microsoft Corporation in the USA and other countries.

NI-VISA is trademark of National Instruments Corp.

Visual Basic 6 and VBA(Excel)

Learn how to create and use TEXIO IOUtils components, controls, data access, and more with the following Visual Basic 6 sample applications.

C.1 Using MEASure? for a Single Measurement

The following example uses the MEASure? command to make a single ac current measurement. This is the easiest way to program the multimeter for measurements. However, MEASure? does not offer much flexibility.

LISTING C.1.

Set the startup object for a Windows application to **Sub Main**.

Add a Reference to the **"VISA Library"**.

The sample application requires the following referece: C:\WINDOWS\system32\visa32.dll.

```
Sub Main()  
  
    Dim stat As ViStatus  
    Dim dfltRM As ViSession  
    Dim sesn As ViSession  
    Dim fList As ViFindList  
    Dim desc As String * VI_FIND_BUFLen  
    Dim nList As Long  
    Dim ret As Long  
    Dim readin As String * 64  
  
    stat = viOpenDefaultRM(dfltRM)  
    If (stat < VI_SUCCESS) Then  
        'Rem Error initializing VISA ... exiting  
        MsgBox "USB-TMC resource not found.", vbExclamation, "DL-1060 multimeter device test"  
        Exit Sub  
    End If  
  
    Rem Find all DL-1060 USB-TMC instruments in the system  
    stat = viFindRsrc(dfltRM, "USB[0-9]*::0x098F::0x2062::?*INSTR", fList, nList, desc)  
    If (stat < VI_SUCCESS) Then  
        'Rem Error finding resources ... exiting  
        MsgBox "DL-1060 device not found.", vbExclamation, "DL-1060 multimeter device test"  
        viClose (dfltRM)  
        Exit Sub  
    End If  
  
    Rem Open a session to each and determine if it matches  
    stat = viOpen(dfltRM, desc, VI_NULL, VI_NULL, sesn)  
    If (stat < VI_SUCCESS) Then
```

```

    MsgBox "Open device failed.", vbExclamation, "DL-1060 multimeter device test"
    stat = viClose(fList)
    Exit Sub
End If
Rem send reset command '*RST' -- reset DL-1060
stat = viWrite(sesn, "*RST", 4, ret)
If (stat < VI_SUCCESS) Then
    MsgBox "System command error. (*RST)", vbExclamation, "DL-1060 multimeter device test"
    stat = viClose(fList)
    Exit Sub
End If
Rem send Clear command '*CLS'-- Clear DL-1060 status register
stat = viWrite(sesn, "*CLS", 4, ret)
If (stat < VI_SUCCESS) Then
    MsgBox "System command error. (*CLS)", vbExclamation, "DL-1060 multimeter device test"
    stat = viClose(fList)
    Exit Sub
End If

Rem send measure command -- Set to 0.1 volt dc range
stat = viWrite(sesn, "meas:volt:DC? 0.1,0.01", 22, ret)
If (stat < VI_SUCCESS) Then
    MsgBox "System command error. (meas:volt:dc? ...)", vbExclamation, "DL-1060 multimeter device
test"
    stat = viClose(fList)
    Exit Sub
End If

Rem fetch the measure data
stat = viRead(sesn, readin, 64, ret)
If (stat < VI_SUCCESS) Then
    MsgBox "Read in data error.", vbExclamation, "DL-1060 multimeter device test"
    stat = viClose(fList)
    Exit Sub
End If

Debug.Print "Rdg = "; readin

Rem set to local mode
stat = viWrite(sesn, "system:local", 12, ret)
If (stat < VI_SUCCESS) Then
    MsgBox "System command error. (system:local)", vbExclamation, "DL-1060 multimeter device test"
    stat = viClose(fList)
    Exit Sub
End If

stat = viClose(sesn)
stat = viClose(fList)
stat = viClose(dfiltRM)

MsgBox "End of Job."

End Sub

```

C.2 Using CONFIGure with a Math Operation

The following example uses CONFIGure with the dBm math operation. The CONFIGure command gives you a little more programming flexibility than the MEASURE? command. This allows you to "incrementally" change the multimeter's configuration.

LISTING C.2.

Set the startup object for a Windows application to **Sub Main**.

Add a Reference to the "VISA Library".

The sample application requires the following reference: C:\WINDOWS\system32\visa32.dll.

```
Public Declare Sub Sleep Lib "kernel32" (ByVal dwMilliseconds As Long)

Sub main()

    Rem #####
    Rem
    Rem     Using NI-VISA library visa32.dll
    Rem
    Rem     Set sample count 5 configuration and
    Rem     read the trigger
    Rem
    Rem #####

    Dim stat As ViStatus
    Dim dfltRM As ViSession
    Dim sesn As ViSession
    Dim fList As ViFindList
    Dim desc As String * VI_FIND_BUFLen
    Dim nList As Long
    Dim ret As Long
    Dim readin As String * 128
    Dim i As Integer      ' Array index

    stat = viOpenDefaultRM(dfltRM)
    If (stat < VI_SUCCESS) Then
        'Rem Error initializing VISA ... exiting
        MsgBox "USB-TMC resource not found.", vbExclamation, "DL-1060 multimeter device test"
        Exit Sub
    End If

    Rem Find all DL-1060 USB-TMC instruments in the system
    stat = viFindRsrc(dfltRM, "USB[0-9]*::0x098F::0x2062::?*INSTR", fList, nList, desc)
    If (stat < VI_SUCCESS) Then
        'Rem Error finding resources ... exiting
        MsgBox "DL-1060 device not found.", vbExclamation, "DL-1060 multimeter device test"
        viClose (dfltRM)
        Exit Sub
    End If

    Rem Open a session to each and determine if it matches
    stat = viOpen(dfltRM, desc, VI_NULL, VI_NULL, sesn)
    If (stat < VI_SUCCESS) Then
        MsgBox "Open device failed.", vbExclamation, "DL-1060 multimeter device test"
        stat = viClose(fList)
        Exit Sub
    End If

    Rem send reset command '*RST' -- reset DL-1060
    stat = viWrite(sesn, "*RST", 4, ret)
```

```

If (stat < VI_SUCCESS) Then
    MsgBox "System command error. (*RST)", vbExclamation, "DL-1060 multimeter device test"
    stat = viClose(fList)
    Exit Sub
End If
Rem send Clear command '*CLS'-- Clear DL-1060 status register
stat = viWrite(sesn, "*CLS", 4, ret)
If (stat < VI_SUCCESS) Then
    MsgBox "System command error. (*CLS)", vbExclamation, "DL-1060 multimeter device test"
    stat = viClose(fList)
    Exit Sub
End If

Rem send command -- 50 ohm reference resistance
stat = viWrite(sesn, "CALC:DBM:REF 50", 15, ret)
If (stat < VI_SUCCESS) Then
    MsgBox "System command error.", vbExclamation, "DL-1060 multimeter device test"
    stat = viClose(fList)
    Exit Sub
End If
Rem send command -- Set kDL-1060 to 1 amp ac range
stat = viWrite(sesn, "CONF:VOLT:AC 1,0.001", 20, ret)
If (stat < VI_SUCCESS) Then
    MsgBox "System command error.", vbExclamation, "DL-1060 multimeter device test"
    stat = viClose(fList)
    Exit Sub
End If
Rem send command -- Select 200 Hz (fast) ac filter
stat = viWrite(sesn, "DET:BAND 200", 12, ret)
If (stat < VI_SUCCESS) Then
    MsgBox "System command error.", vbExclamation, "DL-1060 multimeter device test"
    stat = viClose(fList)
    Exit Sub
End If
Rem send command -- kDL-1060 will accept 5 triggers
stat = viWrite(sesn, "SAMP:COUN 5", 11, ret)
If (stat < VI_SUCCESS) Then
    MsgBox "System command error.", vbExclamation, "DL-1060 multimeter device test"
    stat = viClose(fList)
    Exit Sub
End If
Rem send command -- Trigger source is IMMEDIATE
stat = viWrite(sesn, "TRIG:SOUR IMM", 13, ret)
If (stat < VI_SUCCESS) Then
    MsgBox "System command error.", vbExclamation, "DL-1060 multimeter device test"
    stat = viClose(fList)
    Exit Sub
End If
Rem send command -- Select dBm function
stat = viWrite(sesn, "CALC:FUNC DBM", 13, ret)
If (stat < VI_SUCCESS) Then
    MsgBox "System command error.", vbExclamation, "DL-1060 multimeter device test"
    stat = viClose(fList)
    Exit Sub
End If

Rem send command -- Enable math
stat = viWrite(sesn, "CALC:STAT ON", 12, ret)
If (stat < VI_SUCCESS) Then
    MsgBox "System command error.", vbExclamation, "DL-1060 multimeter device test"
    stat = viClose(fList)
    Exit Sub
End If

```

```

Rem send command -- Take readings
stat = viWrite(sesn, "READ?" & vbLf, 6, ret)
If (stat < VI_SUCCESS) Then
    MsgBox "System command error.", vbExclamation, "DL-1060 multimeter device test"
    stat = viClose(fList)
    Exit Sub
End If

Sleep (3000) ' wait for math processing

Rem fetch the measure data
stat = viRead(sesn, readin, 128, ret)
If (stat < VI_SUCCESS) Then
    MsgBox "Read in data error.", vbExclamation, "DL-1060 multimeter device test"
    stat = viClose(fList)
    Exit Sub
End If

Rem set to local mode
stat = viWrite(sesn, "system:local", 12, ret)
If (stat < VI_SUCCESS) Then
    MsgBox "System command error. (system:local)", vbExclamation, "DL-1060 multimeter device test"
    stat = viClose(fList)
    Exit Sub
End If

stat = viClose(sesn)
stat = viClose(fList)
stat = viClose(dfltRM)

For i = 0 To (5 - 1) ' print out the 4 times samples reading
    Debug.Print "Rdgs = "; Mid(readin, i * 16 + 1, 15)
Next

MsgBox "End of Job."

End Sub

```

Visual C++

This C++ sample application is a Win32 console application. It illustrates how to use the TEXIO IOUtils command. A Win32 console application is a Win32 application that uses text-based input and output, not a graphical interface. This allows you to quickly create a Win32 application by using simple input and output functions.

C.3 THE DEVQUERY FUNCTION

LISTING C.3.

After the path **C:\Program Files\IVI Foundation\VISA\WinNT\include** has been entered, you have to add an "Include" path.

Add **C:\WINDOWS\system32\visa32.dll** to Project folder.

```
// devquery.cpp : Defines the entry point for the console application.
//
// Call the NI-VISA library visa32.dll
//
//

#include "stdafx.h"
#include "visa.h"

//standard include for a Microsoft Visual C++ project
#include "stdio.h"
#include "windows.h"

void main(int argc, char* argv[])
{
    // TODO: Add your control notification handler code here

    HINSTANCE hUSBTMCCLIB;           // for USBTMC HANDLE
    unsigned long m_defaultRM_usbtmc, m_instr_usbtmc;
    unsigned long m_findList_usbtmc;
    unsigned long m_nCount;
    ViStatus status;
    int m_Timeout = 7000;
    char *pStrout;                   // Write out data buffer
    BYTE pStrin[64];                 // Read in data buffer
    int len;
    ULONG nWritten;
    ULONG nRead = 0;
    char buffer[256];
    char instrDescriptor[256];

    // Load the NI-VISA library for USBTMC device
    hUSBTMCCLIB = LoadLibrary("visa32.dll");

    if (!hUSBTMCCLIB)
    {
        MessageBox(NULL, "NIVISA for USBTMC library not found.", "DL-1060 multimeter device test", MB_OK);
        return;
    }

    // Link the libraries
    signed long (__stdcall *PviOpenDefaultRM_usb)(unsigned long *vi);
    signed long (__stdcall *PviFindRsrc_usb)(unsigned long sesn, char *expr, unsigned long *vi,
```

```

        unsigned long *retCnt, char far desc[]);
signed long (__stdcall *PviOpen_usb) (unsigned long sesn, char *name, unsigned long mode,
        unsigned long timeout, unsigned long *vi);
signed long (__stdcall *PviClose_usb) (unsigned long vi);
signed long (__stdcall *PviWrite_usb) (unsigned long vi, unsigned char *name, unsigned long len,
        unsigned long *retval);
signed long (__stdcall *PviRead_usb) (unsigned long vi, unsigned char *name, unsigned long len,
        unsigned long *retval);
signed long (__stdcall *PviSetAttribute_usb) (unsigned long vi, unsigned long viAttr, unsigned long attrstat);

PviOpenDefaultRM_usb = (signed long (__stdcall*)(unsigned long*))GetProcAddress(hUSBTMCLIB,
(LPCSTR)"viOpenDefaultRM");
PviFindRsrc_usb = (signed long (__stdcall*)(unsigned long, char*, unsigned long*,
        unsigned long*, char[]))GetProcAddress(hUSBTMCLIB, (LPCSTR)"viFindRsrc");
PviClose_usb = (signed long (__stdcall*)(unsigned long))GetProcAddress(hUSBTMCLIB,
(LPCSTR)"viClose");
PviOpen_usb = (signed long (__stdcall*)(unsigned long, char*, unsigned long,
        unsigned long, unsigned long*))GetProcAddress(hUSBTMCLIB, (LPCSTR)"viOpen");
PviWrite_usb = (signed long (__stdcall*)(unsigned long, unsigned char*, unsigned long,
        unsigned long*))GetProcAddress(hUSBTMCLIB, (LPCSTR)"viWrite");
PviRead_usb = (signed long (__stdcall*)(unsigned long, unsigned char*, unsigned long,
        unsigned long*))GetProcAddress(hUSBTMCLIB, (LPCSTR)"viRead");
PviSetAttribute_usb = (signed long (__stdcall*)(unsigned long, unsigned long, unsigned
long))GetProcAddress(hUSBTMCLIB, (LPCSTR)"viSetAttribute");

if (PviOpenDefaultRM_usb == NULL ||
    PviFindRsrc_usb == NULL ||
    PviClose_usb == NULL ||
    PviOpen_usb == NULL ||
    PviWrite_usb == NULL ||
    PviRead_usb == NULL ||
    PviSetAttribute_usb == NULL
)
{
    FreeLibrary (hUSBTMCLIB);
    hUSBTMCLIB = NULL;
    MessageBox(NULL, "NIVISA for USBTMC library not ready.", "DL-1060 multimeter device test", MB_OK);
    return;
}

printf("\n ##### Start C++ Example program. #####\n");
printf(" We check the DL-1060 multimeter on USB port and\n");
printf(" identify the first connected DL-1060 device.\n\n");

// Open Device -- Resource Manager
status = PviOpenDefaultRM_usb(&m_defaultRM_usbtmc);
if (status < 0L)
{
    PviClose_usb(m_defaultRM_usbtmc);
    hUSBTMCLIB = NULL;
    m_defaultRM_usbtmc = 0;
    MessageBox(NULL, "USBTMC resource not found.", "DL-1060 multimeter device test", MB_OK);
    return;
}
else
{
    // Find the USBTMC device USB[0-9]*::0x098F::0x2061::?*INSTR ( Dec )
    status = PviFindRsrc_usb (m_defaultRM_usbtmc, "USB[0-9]*::0x098F::0x2062::?*INSTR", &m_findList_usbtmc,
&m_nCount, instrDescriptor);
    if (status < 0L)
    {
        // Find the USBTMC device USB[0-9]*::0x098F::0x2061::?*INSTR ( Hex )
        status = PviFindRsrc_usb (m_defaultRM_usbtmc, "USB[0-9]*::2447::080E::?*INSTR", &m_findList_usbtmc,

```

```

&m_nCount, instrDescriptor);
if (status < 0L)
{
PviClose_usb(m_defaultRM_usbtmc);
hUSBTMCLIB = NULL;
m_defaultRM_usbtmc = 0;
}
else
{
PviOpen_usb(m_defaultRM_usbtmc, instrDescriptor, 0, 0, &m_instr_usbtmc);
status = PviSetAttribute_usb(m_instr_usbtmc, VI_ATTR_TMO_VALUE, m_Timeout);
}
}
else
{
PviOpen_usb(m_defaultRM_usbtmc, instrDescriptor, 0, 0, &m_instr_usbtmc);
status = PviSetAttribute_usb(m_instr_usbtmc, VI_ATTR_TMO_VALUE, m_Timeout);
}
}

if (!hUSBTMCLIB)
{
printf("DL-1060 device connect failed.\n");
return;
}

// Write command "*IDN?" and read the DL-1060 identification string
len = 64;
pStrout = new char[len];
ZeroMemory(pStrout, len);
strcpy(pStrout, "*idn?");
status = PviWrite_usb(m_instr_usbtmc, (unsigned char *)pStrout, 6, &nWritten);
Sleep(30);
if (status != VI_SUCCESS)
{
MessageBox(NULL, "Write to device error.", "DL-1060 multimeter device test", MB_OK);
PviClose_usb(m_defaultRM_usbtmc);
hUSBTMCLIB = NULL;
m_defaultRM_usbtmc = 0;
return;
}
else
{
printf(" output : *IDN?\n");
}
Sleep(1000);
// Read data from device
len = 64;
if (hUSBTMCLIB)
{
status = PviRead_usb(m_instr_usbtmc, pStrin, len, &nRead);
if (nRead > 0)
{
for (len=0; len < (long) nRead; len++)
{
buffer[len] = pStrin[len];
}
}
buffer[nRead] = '\0';
printf(" input : %s\n\n",buffer);
}

// Set sample count to 1
strcpy(pStrout, "SAMP:COUN 1");

```

```

status = PviWrite_usb(m_instr_usbtmc, (unsigned char *)pStrout, 12, &nWritten);
Sleep(30);

// Set configure Voltage AC, range 0.1A
strcpy(pStrout, "CONF:VOLT:AC 0.1,0.01");
status = PviWrite_usb(m_instr_usbtmc, (unsigned char *)pStrout, 22, &nWritten);
Sleep(3000);

// Set configure frequency, range Auto
strcpy(pStrout, "CONF:FREQ");
status = PviWrite_usb(m_instr_usbtmc, (unsigned char *)pStrout, 10, &nWritten);
Sleep(3000);

// Set configure Current DC, range 0.1A
strcpy(pStrout, "CONF:CURR:DC 1,0.01");
status = PviWrite_usb(m_instr_usbtmc, (unsigned char *)pStrout, 20, &nWritten);
Sleep(3000);

// Fetch the DL-1060 measure value ( screen value )
// Set Voltage DC measure
strcpy(pStrout, "CONF:VOLT:DC 0.1,0.1");
status = PviWrite_usb(m_instr_usbtmc, (unsigned char *)pStrout, 21, &nWritten);
Sleep(1000);

// Send read command
strcpy(pStrout, "READ?");
status = PviWrite_usb(m_instr_usbtmc, (unsigned char *)pStrout, 6, &nWritten);
Sleep(30);
printf(" output : READ?\n");

status = PviRead_usb(m_instr_usbtmc, pStrin, 64, &nRead);
if (nRead > 0)
{
for (len=0; len < (long) nRead; len++)
{
buffer[len] = pStrin[len];
}
}
buffer[nRead] = '\0';
printf(" input : %s\n\n", buffer);

// Set device to local mode
strcpy(pStrout, "system:local");
status = PviWrite_usb(m_instr_usbtmc, (unsigned char *)pStrout, 13, &nWritten);
free(pStrout);

// Close device
if (!hUSBTMCLIB)
return;
m_nCount = 0;
m_defaultRM_usbtmc = 0;
FreeLibrary (hUSBTMCLIB);
hUSBTMCLIB = NULL;

return;
}

```



TEXIO TECHNOLOGY CORPORATION

7F Towa Fudosan Shin Yokohama Bild.

2-18-13, Shin Yokohama, Kohoku-ku, Yokohama, Kanagawa, 222-0033 Japan

<http://www.texio.co.jp/>
